

Connecting Solutions Assembly Solutions System Solutions

OETIKER – The experts worldwide



Connecting Technology

- 2 Introduction
- 4 Technical Introduction
- 8 Typical Product Solutions: Vehicle Industry
- 10 Typical Product Solutions: Industry & Trade

14 Ear Clamps

Product Groups 167, 105 & 155, 109, 159 & 163, 153 & 154, 101 & 151

34 Low Profile Clamps

Product Groups 168, 192, 194

50 Screw Clamps and Universal Clamps

Product Groups 178, 180, 174, 126 & 177

64 Multi Crimp Rings

Product Group 150

68 Special Clamps

Product Groups 153, 195, 103, 190

70 Quick Connectors

74 Installation Tools

100 Swing Couplings SC

Introduction

Swiss quality – making the best connections

When you enjoy your daily coffee, your airbag opens when needed, when your train arrives on time and when an operating theatre works perfectly; the Oetiker Group proudly makes its contribution by offering connecting technology for use in almost every aspect of daily life.

The Range: Small parts, great applications.

For nearly 70 years the Oetiker Group has been developing, manufacturing and marketing first class connecting products for vehicles, trade and industry worldwide. The company identifies itself as a partner with its customers, and assists at every stage, from selection advice, through production and sales, to service support.

Oetiker understands the needs of its customers, identifies which products can fulfil individual requirements, and how to develop new solutions. Oetiker's core competence lies primarily in the variety of clamps and rings in a range of materials which are made from tubing or strip. Oetiker manufactures a first class range of products that are outstanding for sealing purposes and for securing hoses and tubes.

Stepless[®], self-tensioning and reusable clamps make connections as durable as they are leak-tight, and contribute around 90% of the group turnover. Substantial added value is created by the comprehensive range of closing tools. Manufactured in our own works, they ensure qualified installation and optimum product performance. Electronically controlled installation tools guarantee verified clamp and ring closure at all times.

Innovative Quick Connectors supplement our range of clamps: They are used to provide simple, fast and reliable fastenings and connections for tubes, hoses and for other, safety-relevant components.

Oetiker also offers a comprehensive assortment of couplings and related items especially for compressed-air systems, and, for the chemical industry, couplings for the

transport of gaseous media that can be operated without causing risk: on one hand, efficient, energy-saving Swing Couplings with unrestricted bores, which are compatible with most common adaptors & nipples and on the other hand, safe and reliable quick-connection couplings with two-stage disconnection.

In addition, Oetiker is the specialist for complete compressed-air systems and can provide you with a complete installation from a single source. Not just couplings, but pipe work, maintenance units, hoses, hose reels, blow guns and other associated accessories.

Finally, Allert, a Group company based in Germany, producing stamped and formed parts, hinged steel belts, and conveyor chains in numerous versions and to the highest quality standards.

Swiss Quality. In tune with the times and in close contact with our customers.

Oetiker stakes its reputation on the success and satisfaction of its customers – based on Swiss quality and reliability, with versatility and safety as well. As a supplier of integrated systems, the company supplies high quality, technically advanced, proven and innovative products in numerous variants for almost any conceivable application. The brand name is registered, and most Oetiker products are patented. Every part supplied by the Oetiker Group is backed by Swiss technology – locally manufactured and customer-oriented.

The Philosophy: Efficient, flexible and innovative.

At the Group headquarters in Horgen, near Zurich, Oetiker has its own research and development department. It works closely with Oetiker Group application centers in the USA, Europe, and Asia Pacific and is able to track market trends and respond to customer-specific requirements. The products used throughout the world are developed and optimized in Horgen using know-how and experience accumulated over many years, and, whether

as part of general product improvement or the development of individual solutions tailored to customer needs, always in the shortest possible time.

Oetiker places equal value on the continuous improvement of manufacturing processes, of production equipment and technologies, which are always state-of-the-art. Quality assurance is a part of every operation, whether in production, as part of an individual service, or a comprehensive service. Only in this way can Oetiker's recognizable quality be made available without restrictions at any location worldwide.

All production companies of the Oetiker Group are certified according to ISO/TS 16949 and ISO 9001 standards and to the environment norm ISO 14001.

**The Oetiker Group: A global player.
And local everywhere.**

Oetiker is globally active and locally present in all markets. Headquartered and managed in Switzerland, the Group is built on a network of 17 local branches and in total a thousand employees, with production and sales companies in Europe, the USA, Canada, China, India and Japan. This enables the Oetiker Group to adapt its range of products precisely to customers' requirements and the local environment – to the market, to the climate, both geographically and culturally. Selected dealers ensure that Oetiker products are available in over 40 countries worldwide.

The Story: Continued success since 1943.

It all began with an ear: in 1943 the company's founder, Hans Oetiker, invented the first ear clamp. This was an innovation that won him worldwide recognition. Still today – continually developed and modified – it remains Oetiker's core product. Over the years the inventive spirit and the will to optimize have created a unique portfolio of products for all manner and varieties of applications. In spite of great success and constant growth, Oetiker

remains a traditional enterprise and is still today owned by the founder's family.

**The Social Aspect: Where people work,
humanity counts.**

The greatest capital asset of the Oetiker Group are its employees, and the individual has appropriate importance in the company's culture. Safety at work and health protection are central concerns, as are systematic training, sound education and continual advanced learning. A commitment that pays rewarding dividends in the long run. Because only people who are competent, who act responsibly, and who enjoy their work can contribute exceptional performance.

The Environment: Consideration pays. For everyone.

Environmental protection is an important part of the company's strategy. Wherever possible we use recyclable materials and, avoid the need for chemical additives. The use of sustainable work processes and the careful treatment of resources, especially energy and raw materials, are equally important. Oetiker goes further still: Every new process and every new material is investigated well before it is introduced to see how it affects planning, production and sales; to find out what lasting effects it will have for employees and customers, and to consider how ecological compatibility can be combined with safety.

Technical introduction

Materials

Only the very highest quality is used in the manufacture of OETIKER Clamps and Rings. The standard material used for the majority of products is stainless steel. The chromium-nickel content of the stainless steel gives excellent corrosion resistance when exposed to a variety of aggressive environmental influences, both atmospheric and aqueous. The specific mechanical and physical characteristics of these materials guarantee high strength and excellent stability.

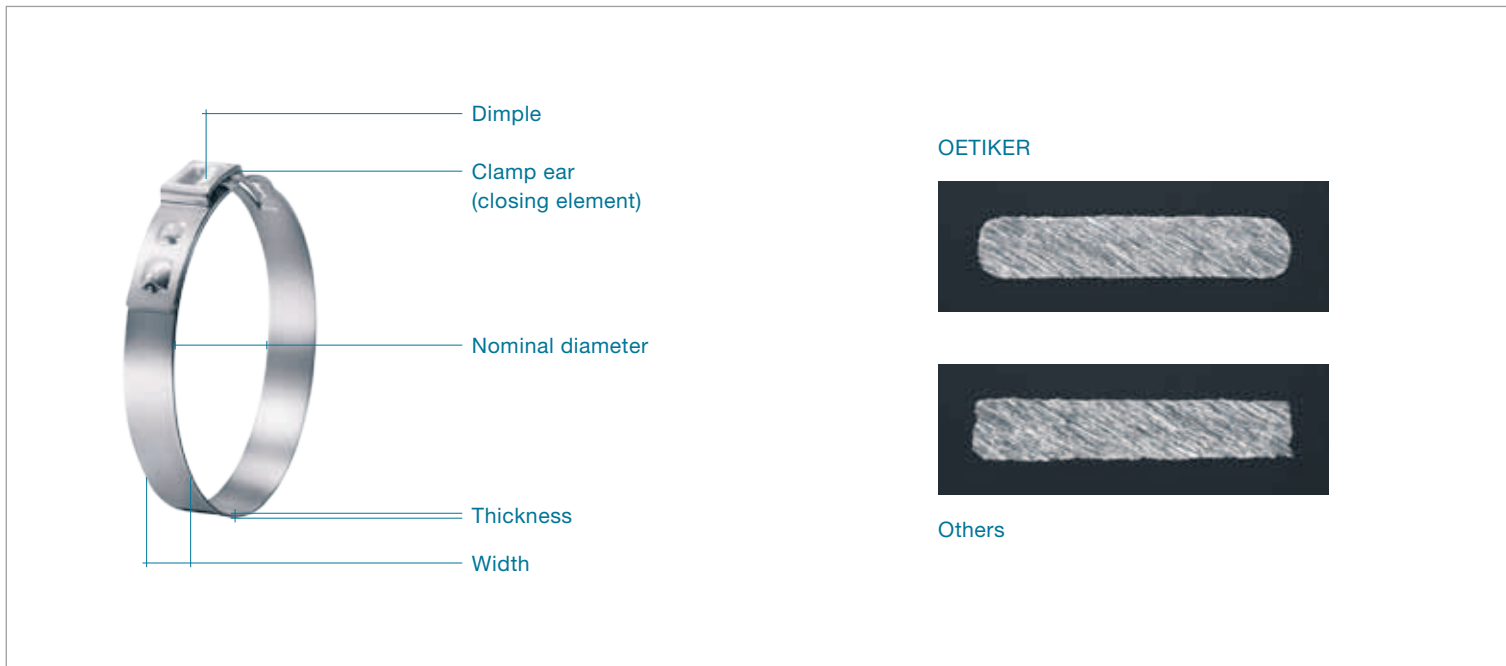

OETIKER Ear Clamp with dimple – the original

The OETIKER system has the ear with a dimple. The geometry of the closed ear is kept very low, which increases the clamping force and creates a spring effect when the hose material expands or contracts in response to thermal or mechanical influences such as temperature, vibration, etc.

Burr-free strip edges

By having its own narrow strip production, OETIKER can guarantee burr-free strip edges. These unique production processes, on the one hand, lower the risk of damage to parts being clamped and, on the other, reduce the danger of injury through heedless handling.

The difference from the edges of conventional strip is hard to see, but technically very significant.

Dimensions, identification and ordering

OETIKER Clamps and Rings are manufactured to metric dimensions. For identification purposes, the nominal diameter is stamped on each product. For example, "145" stands for an open (nominal) clamp diameter of 14.5 mm.

As a general rule, a nominal diameter should be chosen so that the outside diameter of the elastic hose (when assembled onto the connecting part e.g. a hose nozzle) is slightly larger than the middle of the clamping range.

Always quote the 8-digit part number when ordering (see product pages).



Stepless® Design

The unique Stepless® Design means: clamps have no steps or gaps on their inner circumference. They are designed in such a way that, at installation, a metal tongue slides in a corresponding groove. The inside circumference of the clamp that contacts the hose is Stepless® and presses on it around all 360°: for optimum sealing and roundness. This helps you to connect both very soft and very hard materials easily.

The result is effective clamping of a wide variety of hose materials, both extremely soft and extremely hard parts.

Tolerance compensation

By closing the clamp ear with a recommended, uniform force – with force priority – component tolerances within the working range of a Stepless® Ear Clamp can be compensated.

The data in this catalogue are based on many years experience. They are intended for reference, not as design specifications.

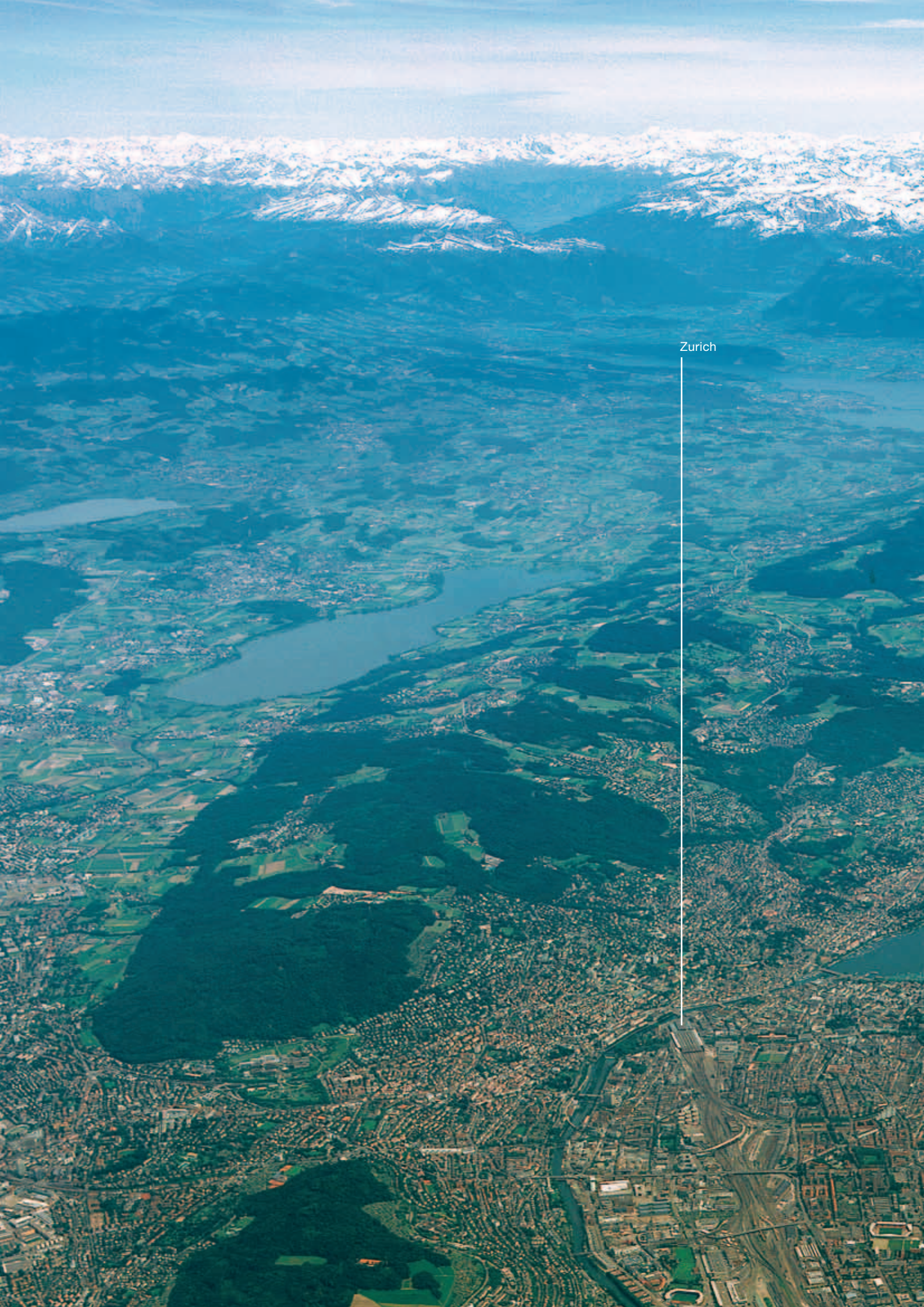

Zurich



Horgen: OETIKER
Headquarters Switzerland



Typical product solutions Vehicle industry

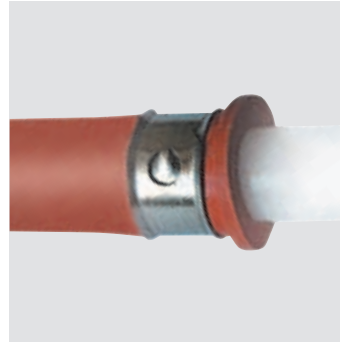

Fuel systems

Cooling and heating
water circuits

Air pipes in low
and high pressure
systems

Stepless® Ear Clamps	PG 167	p. 16	PG 167	PG 167	PG 167	
Stepless® Low Profile Clamps	PG 168	p. 36		PG 168	PG 168	
Stepless® Low Profile Clamps	PG 192	p. 44	PG 192	PG 192	PG 192	
Clamps ER	PG 194	p. 48	PG 194		PG 194	
Worm Drive Clamps	PG 126 & 177	p. 62	PG 126 & 177	PG 126 & 177	PG 126 & 177	
Stepless® Screw Clamps	PG 178	p. 52		PG 178	PG 178	
MINI Worm Drive Clamps	PG 180	p. 56	PG 180			
Multi Crimp Rings	PG 150	p. 66	PG 150	PG 150	PG 150	
1-Ear Clamp with stud	PG 103	p. 69				
1-Ear Clamp SV	PG 153	p. 68				
1-Ear Clamp "Open End"	PG 195	p. 69				



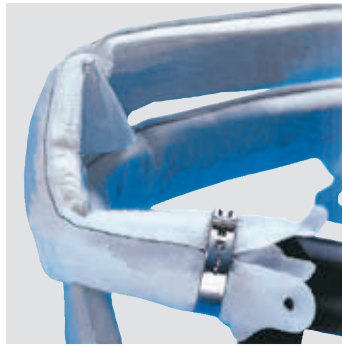

Oil pipes

Cardan shafts/
drive shafts

Steering systems

Airbag systems

Exhaust systems

Other applications

	PG 167	PG 167	PG 167	PG 167	PG 167	PG 167
		PG 168	PG 168			PG 168
	PG 192	PG 192	PG 192			PG 192
					PG 194	PG 194
	PG 126 & 177				PG 126 & 177	PG 126 & 177
	PG 178					
						PG 180
	PG 150	PG 150	PG 150	PG 150	PG 150	PG 150
				PG 103		PG 103
				PG 153		
				PG 195	PG 195	



Typical product solutions

Industry and trade



Agriculture, farm and forestry

Robust, quick connections for reliable service. Flexible installation using manual pincers or battery-operated tools.

PG 101 & 151	p. 29
PG 153 & 154	p. 28
PG 105 & 155	p. 20
PG 109, 159 & 163	p. 24
PG 167	p. 16
PG 174	p. 58
PG 126 & 177	p. 62
PG 180	p. 56

Vehicle repair market

Solutions for flexible, simple and quick installation. A wide range of materials to meet specific application requirements.

PG 101 & 151	p. 29
PG 153 & 154	p. 28
PG 167	p. 16
PG 174	p. 58
PG 126 & 177	p. 62

White goods

Economical connections in numerous different versions – easy and quick to install.

PG 101 & 151	p. 20
PG 167	p. 16

Marine services and ship-building

Robust, flexible products made from high-quality stainless materials for simple, fast installation.

PG 174	p. 58
PG 126 & 177	p. 62
PG 178	p. 52

Military and government operations

Reliable connections, simply and quickly made. Optional versions with specially coated material surfaces.

PG 153 & 154	p. 28
PG 167	p. 16

Electrical and electronic industry

Numerous products for strain relief, for sealing hoses, and for securing cables and other components.

PG 101 & 151	p. 29
PG 153 & 154	p. 28
PG 167	p. 16
PG 126 & 177	p. 62
PG 180	p. 54

Mining, petrochemical and gas industries

Hoses, pipes and cables safely and quickly connected using flexible products.

PG 153 & 154	p. 28
PG 167	p. 16
PG 126 & 177	p. 62

Food and beverage industry

Quick and easy-to-install connections – also in miniature sizes and high-quality stainless materials.

PG 153 & 154	p. 28
PG 167	p. 16





Construction, sanitary	
Secure connections, simply and quickly made. Can be installed using manual pincers or battery-operated tools.	
PG 153 & 154	p. 28
PG 167	p. 16
PG 126 & 177	p. 62
PG 180	p. 56
PG 194	p. 48

Maintenance, repair and service	
Robust, quickly installed connections for many years reliable service.	
PG 101 & 151	p. 29
PG 153 & 154	p. 28
PG 167	p. 16
PG 174	p. 58
PG 126 & 177	p. 62

Medical, chemical and pharmaceutical industry	
Suitable, secure connections – also in miniature sizes and high-quality stainless materials.	
PG 101 & 151	p. 29
PG 153 & 154	p. 28
PG 167	p. 16
PG 180	p. 56
PG 194	p. 48

Train and aviation industry	
Robust, quickly installed connections, including special lightweight versions. Flexible installation using battery-operated tools.	
PG 153 & 154	p. 28
PG 167	p. 16
PG 126 & 177	p. 62
PG 178	p. 52

Welding	
Safe, quick and permanent hose connections.	
PG 153 & 154	p. 28

p. 14

p. 34

Product families

Ear Clamps

Low profile clamps/
Adjustable clamps



Fast and simple installation

High, adaptable radial forces

Compensate for component tolerances

Visible deformation of the ear provides evidence of proper closure

Reusable: can be repeatedly opened and re-installed*

Low installed height, minimum space requirement

Low imbalance on rotating parts

Tolerance compensation*

* depending on the product type

p. 50

Screw clamps, worm drive clamps and universal clamps

p. 64

Multi Crimp Rings

p. 68

Special clamps



Reusable

Large clamping range: can be set to several different nominal diameters*

Fast and simple installation

Compensate for diameter changes due to thermal expansion

Constant, uniform, circumferential compression

Minimum space requirement, no imbalance on rotating parts

Flexible diameter reduction up to 9 mm*

Aluminium model – lightweight

1-Ear Clamps with stud

Stable mountings for components with circular cross-sections

Open clamps: simple, radial installation for ergonomic handling

Application-specific fastenings for exhaust systems

* depending on the product type

* depending on the product type

p. 16

p. 20

Ear Clamps

Stepless® Ear Clamps
PG 167

1-Ear Clamp with mechanical interlock
PG 105 & 155



OETIKER will be pleased to help you find the correct choice for your application. Send sample parts and all relevant information for your specific application to OETIKER, and you will receive recommendations for product type, diameter, and method of installation.

360° Stepless®:

- + Uniform compression or uniform surface pressure

Clamp ear:

- + Compensates for component tolerances

- + Adjustable surface pressure

Dimple:

- + Increased clamping force

- + Spring-effect compensates for changes in diameter due to thermal expansion

Mechanical interlock:

- + Allows use of pre-coated material

Clamp ear:

- + Fast and simple installation

- + Visible deformation provides evidence of proper closure

p.24

Adjustable Clamps
PG 109, 159 & 163

p.28

1-Ear Clamps
PG 153 & 154

p.29

2-Ear Clamps
PG 101 & 151



Choice of engagement positions:
+ Clamp can be adjusted to several nominal diameters
Inner ring with radial guidance:
+ Effective and powerful all-round sealing

Compact one-piece clamps:
+ Robust, secure connections
+ Minimum sizes
With insert:
+ Pre-shaped insert
+ Effective and powerful all-round sealing

2-Ear version:
+ Extended clamping range
Clamp ear:
+ Fast and simple installation
+ Visible deformation of clamp ear provides evidence of proper closure



Narrow band: concentrates transmission of clamping force, less weight

Stepless over 360°: uniform compression or uniform surface pressure

Clamp ear: compensates for component tolerances, adjustable surface pressure

Dimple: increases clamping force, spring-effect compensates for changes in diameter due to thermal expansion

Specially formed strip edges: reduced risk of damage to parts being clamped

Stepless® Ear Clamps Product Group 167

Material

167 Stainless Steel, Material no. 1.4301/UNS S30400

Optional alternative materials

Standard Series

Size range	width x thickness
6.5 – 11.8 mm	5.0 x 0.5 mm
11.9 – 120.5 mm	7.0 x 0.6 mm
21.0 – 120.5 mm	9.0 x 0.6 mm

Heavy Duty Series

Size range	width x thickness
24.5 – 120.5 mm	10.0 x 0.8 mm
62.0 – 120.5 mm	10.0 x 1.0 mm

Some sizes are only available if an appropriate minimum quantity is ordered. Customer specific sizes available on request.

Material thickness

Stepless® Ear Clamps are produced in nominal widths and thicknesses. The selected material dimensions for a specific application are based on the stress required to obtain an adequate seal or load.

Clamp ear (closing element)

The maximum diameter reduction is proportional to the open “ear” width (s).

The theoretical maximum reduction in diameter is given by the formula:

$$\text{Max. diameter reduction} = \frac{\text{Ear-width (s)}}{\pi}$$

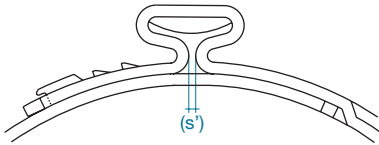

Note: the above sketch shows the appearance of a closed “ear” (s’); it does not necessarily indicate an effective closed assembly.

As a rule, the clamp nominal diameter should be selected so that the outside diameter of the hose, after it has been pushed on to the component to which it is to be fastened (e.g. a hose nipple), is approximately in the middle of the diameter range of the chosen clamp. A clamp can only be considered adequately closed when the ear width (s) has been reduced by at least 40%, and the correct closing force was used for assembly. Further information with assembly recommendations and closing force is available.

Mechanical interlock

The interlock is a mechanical system for joining the clamp ends to permit closure. Some interlock designs can be opened for radial installation prior to closure.

Assembly recommendations

The clamp “ear” is deformed with a constant tool jaw force – this practice is referred to as “force priority closure”. This assembly method ensures that a uniform and repeatable stress is applied to the joint in addition to a consistent tensile force on the clamp interlock. Employing this methodology when closing a 167 series clamp will compensate for any component tolerance variations, and ensure that the clamp applies a constant radial force to the application. Fluctuations in component tolerances are absorbed by variations in the “ear” gap (s’). Clamp installation monitoring and process data collection are available by incorporating an “Electronically Controlled Pneumatic Power Tool” OETIKER ELK 01 in the assembly process.

Closing force

The closing force must be chosen to give the required material compression or surface pressure and should be qualified by dimensional evaluation and experiment. The resistance against the clamp equals the applied force, so the closing force is greatly reduced when compressing a soft material. The table below gives the average applied closing force for clamp and material dimensions when compressing and sealing relatively hard synthetic materials.

Rotation diameter

The rotation diameter (RD) of an assembled clamp can be critical design information for applications that rotate in close proximity to adjacent components. Many factors can influence this final assembly diameter including compression, “ear” gap “s” and material thickness. It is recommended that all variables be considered and evaluated prior to specifying a rotating diameter.

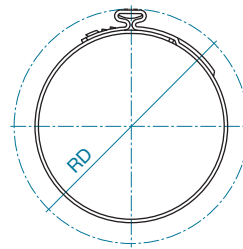

Important

Adding a depressor to the installation tool, for the purpose of reducing the ear height, can cause excessive stress in the ear radii and is not recommended.

Average applied closing force

Material dimensions	Size	Closing force	Manual pincer*	Recommended pneumatic pincer**
5 x 0.5 mm	6.5 – 11.8	1000 N	14100082, 14100083	HO 2000
5 x 0.6 mm	18.5 – 100.0	1700 N	14100082, 14100083	HO 2000
7 x 0.6 mm	11.9 – 17.5	2100 N	14100082, 14100083	HO 2000 – HO 3000
	17.8 – 120.5	2400 N	14100082, 14100083	HO 3000
7 x 0.8 mm		2800 N	14100082, 14100083	HO 3000 – HO 4000
9 x 0.6 mm		2800 N	14100082, 14100083	HO 3000 – HO 4000
9 x 0.8 mm		4100 N	14100097, 14100098	HO 5000 – HO 7000
10 x 0.6 mm		2900 N	14100097, 14100098	HO 5000 – HO 7000
10 x 0.8 mm		5000 N	14100097, 14100098	HO 5000 – HO 7000
10 x 1.0 mm		7000 N	14100097, 14100098	HO 7000
12 x 1.0 mm		8500 N	14100097, 14100098	HO 7000

* 14100082 Standard pincer 14100097 Clamping Tool
 14100083 Standard pincer with side jaws 14100098 Torque wrench

** With appropriate closing force setting

Important note

These figures are intended as a guide, they may vary depending on the type and tolerances of parts being clamped. To ensure optimum clamp selection, we recommend making functional tests with several assemblies.

Order information

Item No. Ref. No. Ear width inside (mm) Size range (mm)

Band width 5 mm, thickness 0.5 mm (505R)

16702488	006.5-505R	4	5.3 – 6.5
16700001	007.0-505R	4	5.8 – 7
16700002	008.0-505R	4	6.8 – 8
16700003	008.7-505R	5.5	7 – 8.7
16702491	009.0-505R	5.5	7.3 – 9
16700004	009.5-505R	5.5	7.8 – 9.5
16700005	010.0-505R	5.5	8.3 – 10
16700006	010.5-505R	5.5	8.8 – 10.5
16702492	010.9-505R	5.5	9.2 – 10.9
16700007	011.3-505R	5.5	9.6 – 11.3
16700008	011.8-505R	5.5	10.1 – 11.8

Band width 7 mm, thickness 0.6 mm (706R)

16702951	011.9-706R	8	9.4 – 11.9
16700009	012.3-706R	8	9.8 – 12.3
16702493	012.8-706R	8	10.3 – 12.8
16700010	013.3-706R	8	10.8 – 13.3
16700011	013.8-706R	8	11.3 – 13.8
16700012	014.0-706R	8	11.5 – 14
16702864	014.2-706R	8	11.7 – 14.2
16700013	014.5-706R	8	12 – 14.5
16700014	014.8-706R	8	12.3 – 14.8
16700015	015.3-706R	8	12.8 – 15.3
16700016	015.7-706R	8	13.2 – 15.7
16702998	016.0-706R	8	13.5 – 16
16702494	016.2-706R	8	13.7 – 16.2
16702495	016.6-706R	8	14.1 – 16.6
16702496	016.8-706R	8	14.3 – 16.8
16700017	017.0-706R	8	14.5 – 17
16702497	017.5-706R	8	15 – 17.5
16700018	017.8-706R	10	14.6 – 17.8
16700019	018.0-706R	10	14.8 – 18
16700020	018.5-706R	10	15.3 – 18.5
16700110	019.2-706R	10	16 – 19.2
16702498	019.8-706R	10	16.6 – 19.8
16700024	021.0-706R	10	17.8 – 21
16700026	022.6-706R	10	19.4 – 22.6
16700028	023.5-706R	10	20.3 – 23.5
16700029	024.1-706R	10	20.9 – 24.1
16700031	025.6-706R	10	22.4 – 25.6
16700033	027.1-706R	10	23.9 – 27.1
16700035	028.6-706R	10	25.4 – 28.6
16702047	030.1-706R	10	26.9 – 30.1
16700039	030.8-706R	10	27.6 – 30.8
16700040	031.6-706R	10	28.4 – 31.6
16700042	033.1-706R	10	29.9 – 33.1
16700044	034.6-706R	10	31.4 – 34.6
16700046	036.1-706R	10	32.9 – 36.1
16700048	037.6-706R	10	34.4 – 37.6
16700050	038.1-706R	10	34.9 – 38.1
16700052	039.6-706R	10	36.4 – 39.6
16700053	041.0-706R	10	37.8 – 41

Item No. Ref. No. Ear width inside (mm) Size range (mm)

Band width 7 mm, thickness 0.6 mm (706R)

16700054	042.5-706R	10	39.3 – 42.5
16700055	044.0-706R	10	40.8 – 44
16700056	045.5-706R	10	42.3 – 45.5
16700057	047.0-706R	10	43.8 – 47
16700058	048.5-706R	10	45.3 – 48.5
16700059	050.0-706R	10	46.8 – 50
16700060	051.5-706R	10	48.3 – 51.5
16700061	053.0-706R	10	49.8 – 53
16700062	054.5-706R	10	51.3 – 54.5
16700063	056.0-706R	10	52.8 – 56
16700064	057.5-706R	10	54.3 – 57.5
16700065	059.0-706R	10	55.8 – 59
16700066	060.5-706R	10	57.3 – 60.5
16700067	062.0-706R	10	58.8 – 62
16700068	063.5-706R	10	60.3 – 63.5
16700069	065.0-706R	10	61.8 – 65
16700070	066.5-706R	10	63.3 – 66.5
16700071	068.0-706R	10	64.8 – 68
16700072	069.5-706R	10	66.3 – 69.5
16700073	071.0-706R	10	67.8 – 71
16700074	072.5-706R	10	69.3 – 72.5
16700075	074.0-706R	10	70.8 – 74
16700076	075.5-706R	10	72.3 – 75.5
16700077	077.0-706R	10	73.8 – 77
16700078	078.5-706R	10	75.3 – 78.5
16700079	080.0-706R	10	76.8 – 80
16700080	081.5-706R	10	78.3 – 81.5
16700081	083.0-706R	10	79.8 – 83
16700082	084.5-706R	10	81.3 – 84.5
16700083	086.0-706R	10	82.8 – 86
16700084	087.5-706R	10	84.3 – 87.5
16700085	089.0-706R	10	85.8 – 89
16700086	090.5-706R	10	87.3 – 90.5
16700087	092.0-706R	10	88.8 – 92
16700088	093.5-706R	10	90.3 – 93.5
16700089	095.0-706R	10	91.8 – 95
16700090	096.5-706R	10	93.3 – 96.5
16700091	098.0-706R	10	94.8 – 98
16700092	099.5-706R	10	96.3 – 99.5
16700093	101.0-706R	10	97.8 – 101
16700094	102.5-706R	10	99.3 – 102.5
16700095	104.0-706R	10	100.8 – 104
16700096	105.5-706R	10	102.3 – 105.5
16700097	107.0-706R	10	103.8 – 107
16700098	108.5-706R	10	105.3 – 108.5
16700099	110.0-706R	10	106.8 – 110
16700100	111.5-706R	10	108.3 – 111.5
16700101	113.0-706R	10	109.8 – 113
16700102	114.5-706R	10	111.3 – 114.5
16700103	116.0-706R	10	112.8 – 116
16700104	117.5-706R	10	114.3 – 117.5
16700105	119.0-706R	10	115.8 – 119
16700106	120.5-706R	10	117.3 – 120.5

Order information

Item No.	Ref. No.	Ear width inside (mm)	Size range (mm)	Item No.	Ref. No.	Ear width inside (mm)	Size range (mm)
Band width 9 mm, thickness 0.6 mm (906R)				Band width 9 mm, thickness 0.6 mm (906R)			
16700196	021.0-906R	10	17.8 – 21	16700262	096.5-906R	10	93.3 – 96.5
16700198	022.6-906R	10	19.4 – 22.6	16700263	098.0-906R	10	94.8 – 98
16703877	023.5-906R	10	20.3 – 23.5	16700264	099.5-906R	10	96.3 – 99.5
16700201	024.1-906R	10	20.9 – 24.1	16700265	101.0-906R	10	97.8 – 101
16700203	025.6-906R	10	22.4 – 25.6	16700266	102.5-906R	10	99.3 – 102.5
16700205	027.1-906R	10	23.9 – 27.1	16700267	104.0-906R	10	100.8 – 104
16700207	028.6-906R	10	25.4 – 28.6	16700268	105.5-906R	10	102.3 – 105.5
16700209	030.1-906R	10	26.9 – 30.1	16700269	107.0-906R	10	103.8 – 107
16700211	030.8-906R	10	27.6 – 30.8	16700270	108.5-906R	10	105.3 – 108.5
16700212	031.6-906R	10	28.4 – 31.6	16700271	110.0-906R	10	106.8 – 110
16700214	033.1-906R	10	29.9 – 33.1	16700272	111.5-906R	10	108.3 – 111.5
16700216	034.6-906R	10	31.4 – 34.6	16700273	113.0-906R	10	109.8 – 113
16700218	036.1-906R	10	32.9 – 36.1	16700274	114.5-906R	10	111.3 – 114.5
16700220	037.6-906R	10	34.4 – 37.6	16700275	116.0-906R	10	112.8 – 116
16702499	038.1-906R	10	34.9 – 38.1	16700276	117.5-906R	10	114.3 – 117.5
16700224	039.6-906R	10	36.4 – 39.6	16700277	119.0-906R	10	115.8 – 119
16700225	041.0-906R	10	37.8 – 41	16700278	120.5-906R	10	117.3 – 120.5
16700226	042.5-906R	10	39.3 – 42.5				
16700227	044.0-906R	10	40.8 – 44	Band width 10 mm, thickness 0.8 mm (1008R)			
16700228	045.5-906R	10	42.3 – 45.5	In the diameter range 24.5 mm to 120.5 mm, these clamps are available in 0.5 mm steps on request.			
16700229	047.0-906R	10	43.8 – 47	Band width 10 mm, thickness 1.0 mm (1010R)			
16700230	048.5-906R	10	45.3 – 48.5	In the diameter range 62 mm to 120.5 mm, these clamps are available in 0.5 mm steps on request.			
16700231	050.0-906R	10	46.8 – 50	Other diameters available on request.			
16700232	051.5-906R	10	48.3 – 51.5				
16700233	053.0-906R	10	49.8 – 53				
16700234	054.5-906R	10	51.3 – 54.5				
16700235	056.0-906R	10	52.8 – 56				
16700236	057.5-906R	10	54.3 – 57.5				
16700237	059.0-906R	10	55.8 – 59				
16700238	060.5-906R	10	57.3 – 60.5				
16700239	062.0-906R	10	58.5 – 62				
16700240	063.5-906R	10	60.3 – 63.5				
16700241	065.0-906R	10	61.8 – 65				
16700242	066.5-906R	10	63.3 – 66.5				
16700243	068.0-906R	10	64.8 – 68				
16700244	069.5-906R	10	66.3 – 69.5				
16700245	071.0-906R	10	67.8 – 71				
16700246	072.5-906R	10	69.3 – 72.5				
16700247	074.0-906R	10	70.8 – 74				
16700248	075.5-906R	10	72.3 – 75.5				
16700249	077.0-906R	10	73.8 – 77				
16700250	078.5-906R	10	75.3 – 78.5				
16700251	080.0-906R	10	76.8 – 80				
16700252	081.5-906R	10	78.3 – 81.5				
16700981	083.0-906R	10	79.8 – 83				
16700254	084.5-906R	10	81.3 – 84.5				
16700255	086.0-906R	10	82.8 – 86				
16700256	087.5-906R	10	84.3 – 87.5				
16700257	089.0-906R	10	85.8 – 89				
16700258	090.5-906R	10	87.3 – 90.5				
16700259	092.0-906R	10	88.8 – 92				
16700260	093.5-906R	10	90.3 – 93.5				
16700261	095.0-906R	10	91.8 – 95				

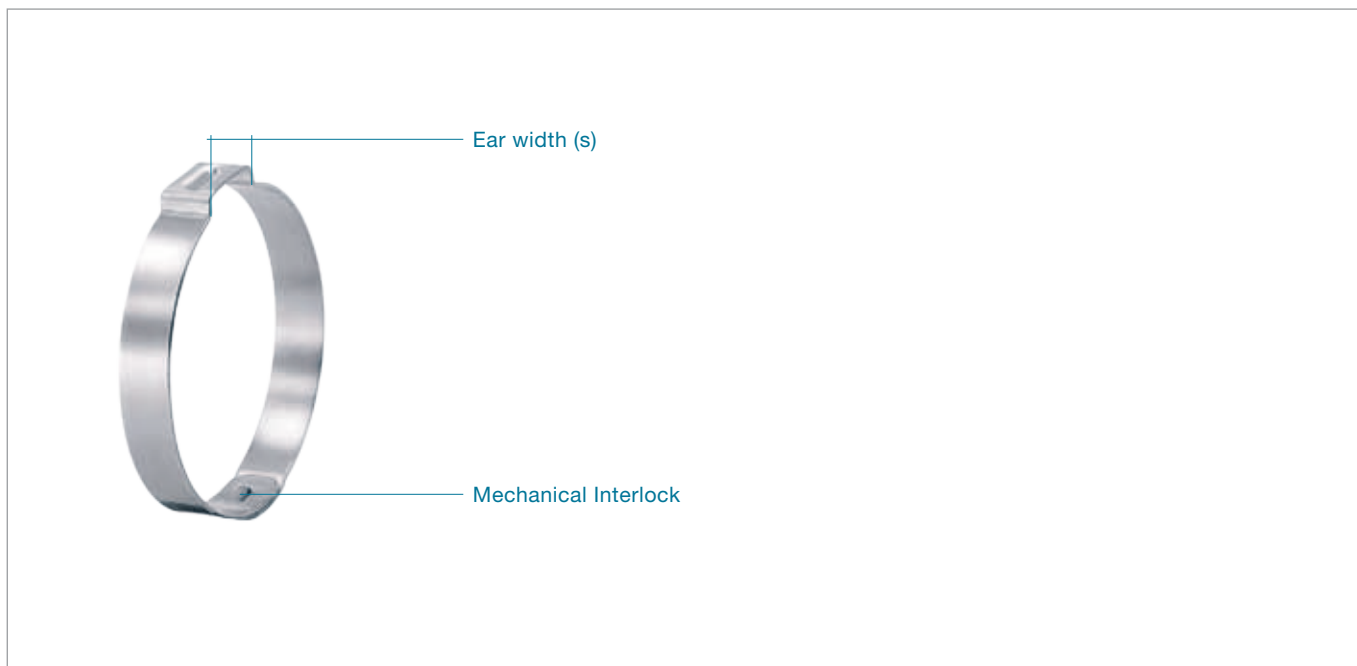

Mechanical interlock: for pre-coated material

Clamp ear: fast and simple installation, visible deformation provides evidence of proper closure

Dimple: increases clamping force, spring-effect compensates for changes in diameter due to thermal and mechanical effects

Specially formed strip edges: reduced risk of damage to parts being clamped

1-Ear Clamp with mechanical interlock Product Group 105 & 155

Material

105 Galvanized or zinc-plated steel band

155 Stainless Steel, Material no. 1.4301/UNS S30400

Series

Size range	width x thickness
10.5 – 116.0 mm	7.0 x 0.6/0.75 mm

Some sizes are only available if an appropriate minimum quantity is ordered.

PG 105 only available on request.

Using tools designed or endorsed by OETIKER, the clamp is closed by drawing together the lower radii of the “ear”. The maximum diameter reduction is proportional to the open “ear” width. The theoretical maximum reduction in diameter is given by the formula:

$$\text{Max. diameter reduction} = \frac{\text{Ear-width (s)}}{\pi}$$

To ensure perfect sealing, clamp ears must be correctly closed during installation.

Clamp diameter

As a guide, the clamp nominal diameter should be selected so that the outside diameter of the hose, after it has been pushed on to the component to which it is to be fastened (e.g. a hose nipple), is approximately in the middle of the diameter range of the chosen clamp.

Mechanical interlock

The mechanical interlock is a mechanical connection which keeps the clamp securely closed. By using a mechanical interlock instead of spot-welding, corrosion around the closure elements is reduced.

Assembly recommendations

The clamp ear should be closed with a constant tool jaw force, this practice is referred to as “force priority closure”. This assembly method ensures that a uniform and repeatable stress is applied to the application with a constant tensile force on the mechanical interlock.

Employing this methodology when closing 105 & 155 series clamps will compensate for any component tolerance variations, and ensure that the clamp applies a constant radial force to the application. Fluctuations in component tolerances are absorbed by variations in the “ear” gap (the space between the lower radii after installation).

Clamp installation monitoring equipment and process data collection are available by incorporating an “Electronically Controlled Assembly Tool” OETIKER ELK01 in the assembly process.

Closing force

It is important to realize that there is in a very close relationship between the desired compression of the material being clamped and the closing force selected. The table below gives average closing forces in relation to the size of the part being clamped.

Average applied closing force

Material dimensions	Closing force GALFAN/Stainless	Manual pincer*	Recommended pneumatic pincer**
10.5 – 17.0	1200 N	14100082, 14100083	HO 2000
18.5 – 116.0	2000 N	14100082, 14100083	HO 2000

* 14100082 Standard pincer

14100083 Standard pincer with side jaws

** With appropriate closing force setting

Important note

These figures are intended as a guide, they may vary depending on the type and tolerances of parts being clamped. To ensure optimum clamp selection, we recommend making functional tests with several assemblies.

Order information

Item No. Ref. No. Ear width inside (mm) Size range (mm)

1-Ear Clamp with mechanical Interlock, stainless
Band width 7 mm, thickness 0.6 mm

15500000	0105.0R	5	8.9 – 10.5
15500001	0113.0R	5	9.7 – 11.3
15500002	0123.0R	6	10.4 – 12.3
15500003	0133.0R	6	11.4 – 13.3
15500004	0135.0R	6.5	11.5 – 13.5
15500005	0138.0R	6	11.9 – 13.8
15500006	0140.0R	6.5	11.9 – 14
15500007	0145.0R	6	12.6 – 14.5
15500008	0157.0R	7	13.5 – 15.7
15500009	0170.0R	6	15.1 – 17
15500010	0185.0R	9	15.7 – 18.5
15500011	0198.0R	9	17 – 19.8
15500012	0210.0R	9	18.2 – 21
15500013	0226.0R	9	19.8 – 22.6
15500014	0241.0R	9	21.3 – 24.1
15500015	0256.0R	9	22.8 – 25.6
15500016	0271.0R	10	24 – 27.1
15500017	0286.0R	10	25.5 – 28.6
15500018	0301.0R	10	27 – 30.1
15500019	0316.0R	10	28.5 – 31.6
15500020	0331.0R	10	30 – 33.1
15500021	0346.0R	10	31.5 – 34.6
15500022	0361.0R	10	33 – 36.1
15500023	0376.0R	10	34.5 – 37.6
15500024	0381.0R	10	35 – 38.1
15500025	0396.0R	10	36.5 – 39.6

Item No. Ref. No. Ear width inside (mm) Size range (mm)

1-Ear Clamp with mechanical Interlock, stainless
Band width 7 mm, thickness 0.6 mm

15500026	0410.0R	10	37.9 – 41
15500027	0425.0R	10	39.4 – 42.5
15500028	0440.0R	10	40.9 – 44
15500029	0455.0R	10	42.4 – 45.5
15500030	0470.0R	10	43.9 – 47
15500031	0485.0R	10	45.4 – 48.5
15500032	0500.0R	10	46.9 – 50
15500033	0515.0R	10	48.4 – 51.5
15500034	0530.0R	10	49.9 – 53
15500035	0545.0R	10	51.4 – 54.5
15500036	0560.0R	10	52.9 – 56
15500037	0575.0R	10	54.4 – 57.5
15500038	0590.0R	10	55.9 – 59
15500039	0605.0R	10	57.4 – 60.5
15500040	0620.0R	10	58.9 – 62
15500041	0635.0R	10	60.4 – 63.5
15500042	0650.0R	10	61.9 – 65
15500043	0665.0R	10	63.4 – 66.5
15500044	0680.0R	10	64.9 – 68
15500045	0695.0R	10	66.4 – 69.5
15500046	0710.0R	10	67.9 – 71
15500047	0725.0R	10	69.4 – 72.5
15500048	0740.0R	10	70.9 – 74
15500049	0755.0R	10	72.4 – 75.5
15500050	0770.0R	10	73.9 – 77
15500051	0785.0R	10	75.4 – 78.5

Order information

Item No.	Ref. No.	Ear width inside (mm)	Size range (mm)
----------	----------	--------------------------	-----------------

1-Ear Clamp with mechanical Interlock, stainless
Band width 7 mm, thickness 0.6 mm

15500052	0800.0R	10	76.9 – 80
15500053	0815.0R	10	78.4 – 81.5
15500054	0830.0R	10	79.9 – 83
15500055	0845.0R	10	81.4 – 84.5
15500056	0860.0R	10	82.9 – 86
15500057	0875.0R	10	84.4 – 87.5
15500058	0890.0R	10	85.9 – 89
15500059	0905.0R	10	87.4 – 90.5
15500060	0920.0R	10	88.9 – 92
15500061	0935.0R	10	90.4 – 93.5
15500062	0950.0R	10	91.9 – 95
15500063	0965.0R	10	93.4 – 96.5
15500064	0980.0R	10	94.9 – 98
15500065	0995.0R	10	96.4 – 99.5
15500066	1010.0R	10	97.9 – 101
15500067	1025.0R	10	99.4 – 102.5
15500101	1040.0R	10	100.9 – 104
15500068	1055.0R	10	102.4 – 105.5
15500102	1070.0R	10	103.9 – 107
15500103	1085.0R	10	105.4 – 108.5
15500104	1100.0R	10	106.9 – 110
15500105	1115.0R	10	108.4 – 111.5
15500106	1130.0R	10	109.9 – 113
15500107	1145.0R	10	111.4 – 114.5
15500069	1160.0R	10	112.9 – 116

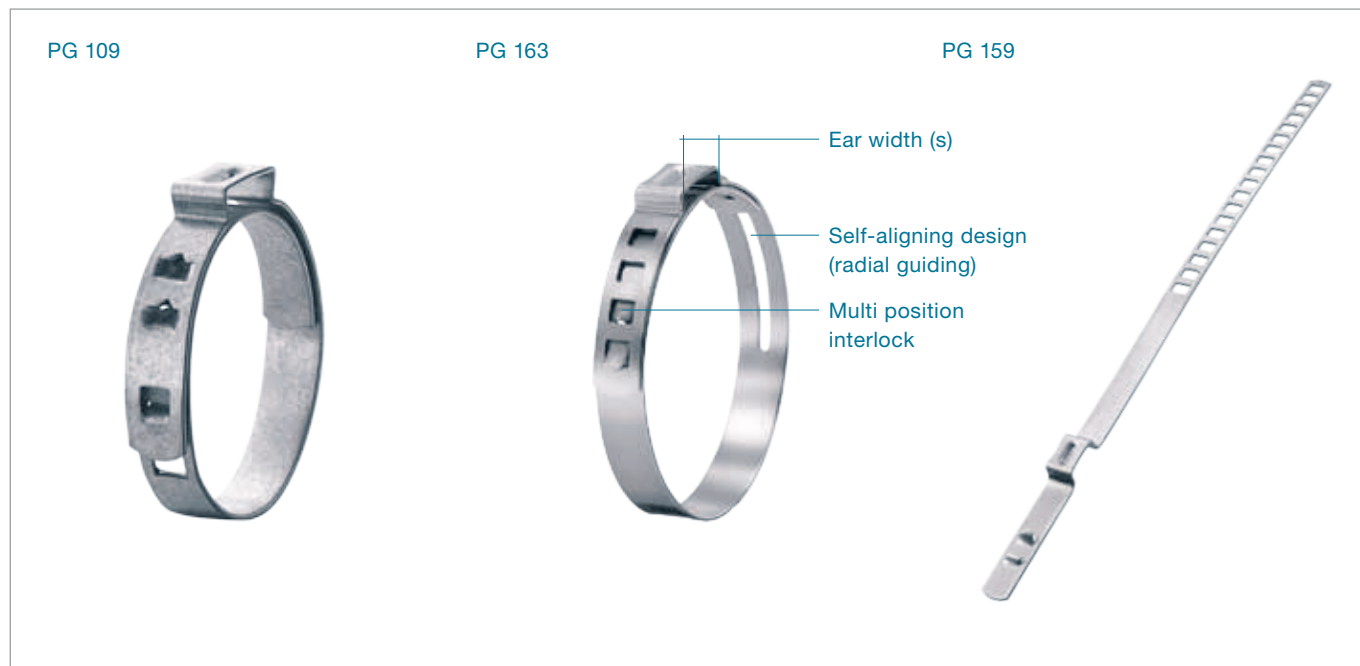

Choice of engagement positions: clamp can be adjusted to several nominal diameters

Inner ring with radial guidance: effective and powerful all-round sealing

Clamp ear: simple and fast installation, visible deformation provides evidence of proper closure

Specially formed strip edges: reduced risk of damage to parts being clamped

Adjustable Clamps Product Group 109, 159 & 163

Material

109 zinc-plated steel band

159 & 163 Stainless Steel, Material no. 1.4301/UNS S30400

Adjustable Clamps PG 109

Size range	width x thickness
29.5 – 122.0 mm	7.0 x 0.75 mm
29.5 – 122.0 mm	9.0 x 0.75 mm

Adjustable Clamps PG 159

Size range	width x thickness
25.0 – 50.0 mm	7.0 x 0.8 mm*
40.0 – 110.0 mm	7.0 x 0.8 mm*

Adjustable Clamps with radial guiding PG 163

Size range	width x thickness
30.0 – 116.0 mm	7.0 x 0.6 mm
72.0 – 132.0 mm	9.0 x 0.6 mm

* Diameter range covered by a single clamp

Some sizes are only available if an appropriate minimum quantity is ordered.

Product Group 159 – Adjustable Clamps:

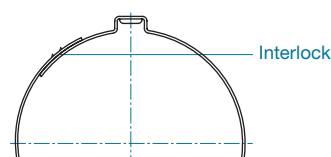

Version with interlock outside
May make installation easier

Product Group 109/159 – Adjustable clamp:

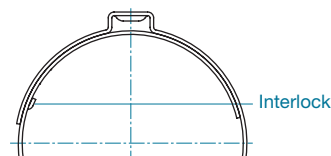

Version with interlock inside

Using tools designed by OETIKER, the clamp is closed by drawing together the lower radii of the “ear”. The maximum diameter reduction is proportional to the open “ear” width (s). The theoretical maximum reduction in diameter is given by the formula:

$$\frac{(\text{Ear width}) 10 \text{ mm}^*}{\pi} = 3.2 \text{ mm}$$

* Adjustable Clamps with radial guiding, 8.5 mm ear-width (2.7 mm theoretical diameter reduction) with Adjustable Clamps PG 159

Multi-position interlock

The interlock consists of one or two load-retaining hooks that withstand tensile loading during closure and a lock tab designed to hold the hooks in their windows prior to closure. With both designs the interlock can be engaged in several positions within the published range. This feature allows a single part to cover a range of diameters.

Adjustable Clamps with radial guiding (self-aligning design)

A tab formed on the inner portion of the clamp locates in a slot in the outer band surface. During assembly and closure, the tab slides in the slot and so avoids any step around the inner circumference of the clamp.

Assembly Recommendations

Product Group 163 – Adjustable Clamps with radial guiding

The clamp can be installed axially on the application prior to assembly or alternatively, radially around the assembled components. For either method, it is important that the hooks and lock tab are engaged in windows giving the smallest possible

diameter, so that the maximum clearance between the assembled components and the inside diameter of the clamp before closure is no greater than 1.5 mm. Each incremental step of the interlock reduces the diameter before closure by 1.6 mm on the “3-step” series, and by 1.05 mm on the “6- step” design.

Product Group 109&159 – Adjustable Clamps

PG 109 Adjustable Clamps are supplied pre-shaped and engaged at mid-diameter. PG 159 clamps are supplied flat. The clamp must be shaped prior to assembly. Each incremental step of the interlock reduces the diameter before closure by approximately 1.6 mm. The following assembly steps demonstrate how best to achieve an effective geometry.

The clamp ear of both variants should be closed with constant tool jaw force, this practice is referred to as “force priority closure”. This assembly method ensures that a uniform and repeatable stress is applied to the application with a constant tensile force on the mechanical interlock.

Clamp installation monitoring and process data collection are available by incorporating an “Electronically Controlled Pneumatic Power Tool OETIKER ELK 01” in the assembly process.

Closing force

The closing force must be chosen to give the required material compression or surface pressure and should be qualified by dimensional evaluation and experiment. The resistance against the clamp equals the applied force, so the closing force is greatly reduced when compressing a soft material. The table below gives the average applied closing force for clamp and material dimensions.

Average applied closing force

Material dimensions	Size (mm)	Closing force	Manual pincer*	Recommended pneumatic pincer**
Product Group 109				
7 x 0.75 mm	29.5 – 122	1400 N	14100082, 14100083	HO 2000
9 x 0.75 mm	29.5 – 122	1800 N	14100082, 14100083	HO 2000
Product Group 159				
7 x 0.8 mm	25 – 50	2400 – 2700 N	14100082, 14100083	HO 3000
7 x 0.8 mm	40 – 110	2400 – 2700 N	14100082, 14100083	HO 3000
Product Group 163				
7 x 0.6 mm	30 – 50	1800 – 2100 N	14100082, 14100083	HO 2000 – HO 3000
7 x 0.6 mm	56 – 116	2400 – 2700 N	14100082, 14100083	HO 3000
9 x 0.6 mm	72 – 132	2800 – 3200 N	14100082, 14100083	HO 3000

* 14100082 Standard pincer/14100083 Standard pincer with side jaws

** With appropriate closing force setting

Important note

These figures are intended as a guide, they may vary depending on the type and tolerances of parts being clamped. To ensure optimum clamp selection, we recommend making functional tests with several assemblies.

Assembly instructions

PG 159 – Version with interlock outside



Step 1
Pre-shape clamp.



Step 2
Determine the clamp length.



Step 3
Cut off the remaining material.
To avoid possible injury deburr cut edges with a file.



Step 4
Place the clamp over object.
Engage interlocking hooks in tightest window position.
Firmly crimp the ear with OETIKER pincers.

PG 109 & 159 – Version with interlock inside



Step 1
Pre-shape clamp.



Step 2
Determine the clamp length.
Make sure the end of the clamp passes the "ear", as shown.



Step 3
Cut off the remaining material.
To avoid possible injury deburr cut edges with a file.



Step 4
Place the clamp over object.
Engage interlocking hooks in tightest window position.
Firmly crimp the ear with OETIKER pincers.

Order information

Item No.	Ref. size*	Diameter range (mm)
----------	------------	---------------------

Product Group 109

Band width 7 mm, thickness 0.75 mm, Ear width 10 mm

10900012	29.5	24.5 – 29.5
10900016	34.2	29.5 – 36.0
10900018	42.3	36.0 – 45.5
10900020	55.1	45.5 – 61.5
10900022	74.3	61.5 – 85.5
10900014	106.1	85.5 – 122.0

Band width 9 mm, thickness 0.75 mm, Ear width 10 mm

10900013	29.5	24.5 – 29.5
10900017	34.2	29.5 – 36.0
10900019	42.3	36.0 – 45.5
10900021	55.1	45.5 – 61.5
10900023	74.3	61.5 – 85.5
10900015	106.1	85.5 – 122.0

Item No.	Diameter range (mm)	Width x thickness
----------	---------------------	-------------------

Interlock outside/inside

Product Group 159

15900002/15900005	25 – 50 mm	7 x 0.8 mm
15900004/15900007	40 – 110 mm	7 x 0.8 mm

Item No.	Ref. size*	Diameter range (mm)	Diameter range (inch)
----------	------------	---------------------	-----------------------

Product Group 163

3 adjustment positions

Band width 7 mm, thickness 0.6 mm, Ear width 10 mm

16300022	30	23.6 – 30.0	0.929 – 1.181
16300179	32	25.6 – 32.0	1.008 – 1.260
16300023	35	28.6 – 35.0	1.126 – 1.378
16300251	37	30.6 – 37.0	1.205 – 1.457
16300024	40	33.6 – 40.0	1.323 – 1.575
16300025	45	38.6 – 45.0	1.520 – 1.772
16300026	50	43.6 – 50.0	1.717 – 1.969

6 adjustment positions

Band width 7 mm, thickness 0.6 mm, Ear width 10 mm

16300027	56	47.5 – 56.0	1.870 – 2.205
16300028	62	53.5 – 62.0	2.106 – 2.441
16300029	68	59.5 – 68.0	2.343 – 2.677
16300030	74	65.5 – 74.0	2.579 – 2.913
16300031	80	71.5 – 80.0	2.815 – 3.150
16300032	86	77.5 – 86.0	3.051 – 3.386
16300033	92	83.5 – 92.0	3.287 – 3.622
16300051	94	85.5 – 94.0	3.366 – 3.701
16300034	98	89.5 – 98.0	3.524 – 3.858
16300035	104	95.5 – 104.0	3.760 – 4.094
16300250	107	98.5 – 107.0	3.878 – 4.213
16300036	110	101.5 – 110.0	3.996 – 4.331
16300037	116	107.5 – 116.0	4.232 – 4.567

4 adjustment positions

Band width 9 mm, thickness 0.6 mm, Ear width 10 mm

16300038	72	64.0 – 72.0	2.520 – 2.835
16300039	78	70.0 – 78.0	2.756 – 3.071
16300040	84	76.0 – 84.0	2.992 – 3.307
16300041	90	82.0 – 90.0	3.228 – 3.543
16300042	96	88.0 – 96.0	3.465 – 3.780
16300043	102	94.0 – 102.0	3.701 – 4.016
16300044	108	100.0 – 108.0	3.937 – 4.252
16300046	114	106.0 – 114.0	4.173 – 4.488
16300045	120	112.0 – 120.0	4.409 – 4.724
16300053	126	118.0 – 126.0	4.645 – 4.961
16300129	132	124.0 – 132.0	4.882 – 5.197

* Ref. size = Condition as supplied:
Formed and engaged at the mid-diameter.



Compact one-piece clamp: for robust, secure connections, miniature sizes

Clamp ear: fast and simple installation, visible deformation provides evidence of proper closure

Deburred edges: reduced risk of damage to parts being clamped

With insert

Pre-shaped insert: effective and powerful all-round seal

1-Ear Clamps Product Group 153/154

Material

153 Stainless Steel, Material no. 1.4301/UNS S30400

154 Clamp: Stainless Steel, Material no. 1.4301/UNS S30400

Insert: Stainless Steel, Material no. 1.4310/UNS S30100

Size range

153 3.3 – 30.7 mm

154 2.9 – 30.0 mm

Some sizes are only available if an appropriate minimum quantity is ordered.

Process

The manufacturing process for OETIKER 1-Ear and 2-Ear Clamps commences with the spiral roll-forming and welding of raw material into lengths of tube, a technique developed to obtain a robust, continuous welded ring.

OETIKER 1-Ear Clamps with insert

This type of clamp combines the geometry and properties of the 1-Ear Clamp with an insert made of stainless steel.

These clamps are ideal for demanding applications involving soft or hard rubbers and plastics. The thin-walled insert ring (up to 0.3 mm thick), with an oval protrusion that locates in the ear space, bridges the ear gap and ensures almost uniform compression around the whole circumference of a clamp.

Edge condition

Burrs generated during the shearing and forming processes are entirely eliminated in a barrel-finishing operation.

Closure

By using an OETIKER closing tool to pinch the clamp ear, the diameter of the clamp is reduced. This diameter reduction is proportional to the ear width.

The maximum reduction in diameter is given by the formula:

$$\text{Max. diameter reduction} = \frac{\text{Ear-width (s)}}{\pi}$$

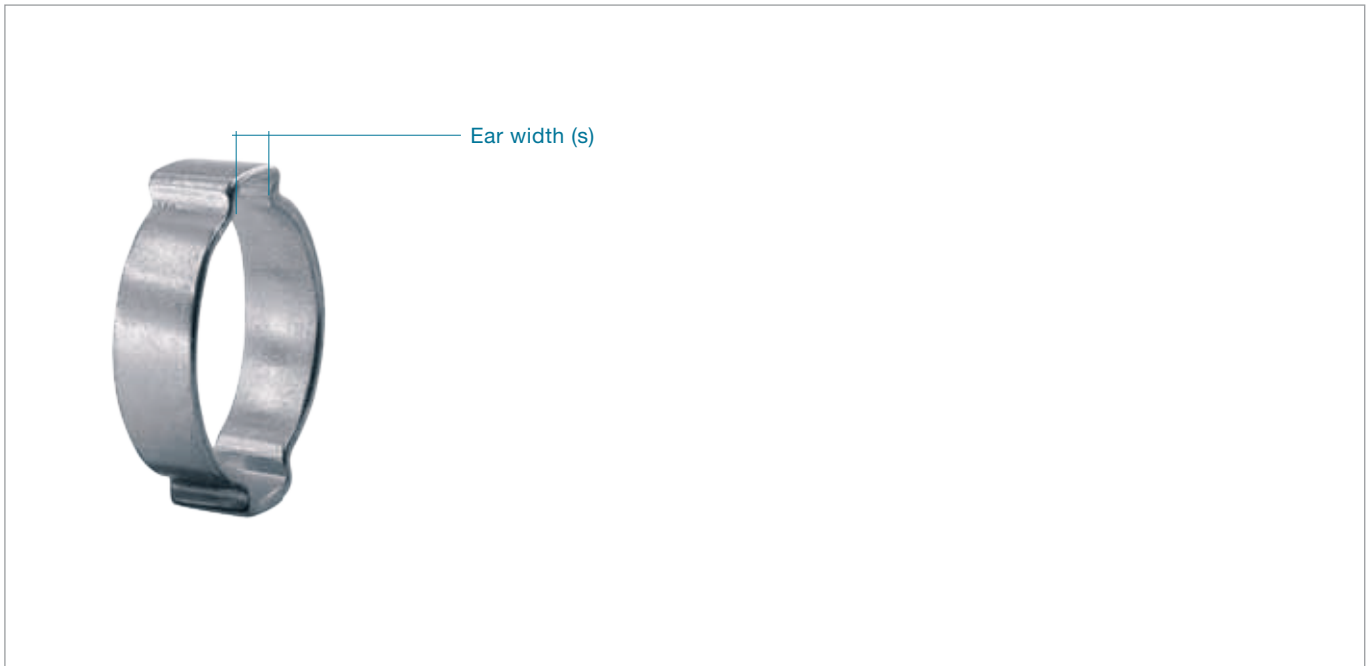

2-Ear version: [extended clamping range](#)

Compact one-piece clamp: [for robust, secure connections](#)

Clamp ear: [fast and simple installation, visible deformation provides evidence of proper closure](#)

Deburred edges: [reduced risk of damage to parts being clamped](#)

2-Ear Clamps Product Group 101 & 151

Material

101 Steel, Material no. 1.0338/SAE 1008/1010, zinc-plated

151 Stainless Steel, Material no. 1.4301/UNS S30400

Size range

4.1 – 46.0 mm

[Some sizes are only available if an appropriate minimum quantity is ordered.](#)

OETIKER 2-Ear Clamps

The ears of these clamps do not have a dimple and nearly double the clamping range, compared to the 1-ear clamp. 2 ears provide a degree of elasticity to accommodate changes in size of the parts being joined, such as that which may be caused by thermal expansion or vibration.

Installation techniques are similar to those for 1-Ear Clamps, but the force applied when closing the second ear may react against the opposing closed ear and make a second crimping operation necessary. For perfect sealing, the ears must be adequately closed during installation.

Assembly recommendations

The ears of these clamps should be closed with the recommended, uniform force (known as force priority). This method will result in a constant, reproducible stress within the clamp material, without overloading either the clamp or the parts being assembled. The nominal diameter of the clamp should always be chosen so that, when installed with the correct clamping force, the ears are almost closed.

Complete process monitoring and 100% process documentation are available using the “Electronically Controlled Pneumatic Power Tool” OETIKER ELK 01.

Closing force

The following table shows the average applied closing force for different material dimensions.

Average applied closing force

Material dimensions	Closing force (N)		Manual pincer*	Recommended pneumatic pincer**
	Zinc-plated steel	Stainless		
Product Group 153				
03.3 – 11.0	–	1400	14100082, 14100083	HO 2000
11.3 – 20.7	–	2300	14100082, 14100083	HO 3000
21.0 – 30.7	–	2800	14100082, 14100083	HO 3000
Product Group 154				
03.3 – 11.8	–	1500	14100082, 14100083	HO 2000
12.0 – 20.7	–	2500	14100082, 14100083	HO 3000
21.0 – 30.7	–	3600	14100082, 14100083	HO 4000
Product Group 101 & 151				
0041 – 1720	2200	2500	14100082, 14100083	HO 3000
1922 – 4346	3400	3600	14100082, 14100083	HO 4000

* 14100082 Standard pincer

14100083 Standard pincer with side jaws

** With appropriate closing force setting

Important note

These figures are intended as a guide, they may vary depending on the type and tolerances of parts being clamped. To ensure optimum clamp selection, we recommend making functional tests with several assemblies.

Order information

Item No.	Ref. No.	Ear width inside (mm)	Size range (mm)	Item No.	Ref. No.	Ear width inside (mm)	Size range (mm)
1-Ear Clamps, stainless				1-Ear Clamps, stainless			
15300000	03.3R	1.4	2.9 – 3.3	15300021	13.3R	6.5	11.3 – 13.3
15300001	03.5R	1.4	3 – 3.5	15300022	13.8R	6.5	11.8 – 13.8
15300002	04.1R	2.5	3.3 – 4.1	15300023	14.0R	6.5	12 – 14
15300054	04.6R	3	3.8 – 4.6	15300024	14.5R	6.5	12.5 – 14.5
15300003	05.1R	3.2	4.1 – 5.1	15300025	15.0R	6.5	13 – 15
15300055	05.6R	3.2	4.6 – 5.6	15300026	15.5R	6.5	13.5 – 15.5
15300004	06.1R	3.2	5.1 – 6.1	15300027	16.0R	7	13.8 – 16
15300005	06.6R	3.2	5.6 – 6.6	15300028	16.5R	8	14 – 16.5
15300006	07.0R	3	6.1 – 7	15300029	16.8R	7	14.6 – 16.8
15300007	07.5R	3.5	6.5 – 7.5	15300030	17.5R	7	15.3 – 17.5
15300008	08.0R	4	6.8 – 8	15300031	18.5R	7	16.3 – 18.5
15300009	08.3R	4	7.1 – 8.3	15300032	19.5R	7.5	17.2 – 19.5
15300010	08.7R	4	7.5 – 8.7	15300033	20.0R	7.5	17.7 – 20
15300011	09.0R	5	7.5 – 9	15300034	20.7R	9	17.9 – 20.7
15300012	09.5R	5	8.1 – 9.5	15300035	21.0R	7.5	18.7 – 21
15300013	10.0R	5	8.5 – 10	15300036	21.8R	7.5	19.5 – 21.8
15300014	10.5R	5	9.1 – 10.5	15300037	22.5R	8.5	19.9 – 22.5
15300015	11.0R	5.5	9.3 – 11	15300038	23.5R	8.5	21 – 23.5
15300016	11.3R	5.5	9.6 – 11.3	15300040	24.5R	9	21.7 – 24.5
15300017	11.8R	5.5	10.1 – 11.8	15300041	25.5R	9	22.7 – 25.5
15300018	12.0R	6.5	10.1 – 12	15300043	26.3R	8.5	23.6 – 26.3
15300019	12.3R	6.5	10.3 – 12.3	15300044	27.0R	9.5	24.1 – 27
15300020	12.8R	6.5	10.8 – 12.8	15300045	30.7R	11	27.2 – 30.7

Order information

Item No.	Ref. No.	Ear width inside (mm)	Size range (mm)	Item No.	Ref. No.	Size range (mm)
1-Ear Clamps with insert, stainless				2-Ear Clamps, zinc-plated		
15400010	03.3RER	1.4	2.5 – 2.9	10100000	0041	3.1 – 4.1
15400011	03.5RER	1.4	2.7 – 3.1	10100001	0045	3.5 – 4.5
15400012	04.1RER	2.5	2.9 – 3.7	10100002	0305	3.4 – 5
15400063	04.6RER	3	3.4 – 4.2	10100004	0507	5 – 7
15400013	05.1RER	3.2	3.7 – 4.7	10100008	0709	7 – 9
15400064	05.6RER	3.2	4.2 – 5.2	10100011	0811	8.1 – 11
15400014	06.1RER	3.2	4.7 – 5.7	10100016	1113	10.8 – 13
15400015	06.6RER	3.2	5.2 – 6.2	10100019	1315	12.5 – 15
15400016	07.0RER	3	5.6 – 6.5	10100022	1517	14 – 17
15400017	07.5RER	3.5	5.9 – 7	10100097	1619	16 – 19
15400018	08.0RER	4	6.3 – 7.5	10100027	1720	16.2 – 20
15400019	08.3RER	4	6.6 – 7.8	10100029	1922	18 – 22
15400020	08.7RER	4	7 – 8.2	10100030	2023	19 – 23
15400021	09.0RER	5	7 – 8.5	10100032	2225	21 – 25
15400022	09.5RER	5	7.5 – 9	10100034	2327	22.5 – 27
15400023	10.0RER	5	8 – 9.5	10100035	2528	24 – 28
15400024	10.5RER	5	8.5 – 10	10100037	2731	26.3 – 31
15400025	11.0RER	5.5	8.8 – 10.5	10100041	3134	29.3 – 34
15400026	11.3RER	5.5	9.1 – 10.8	10100043	3437	32 – 37
15400027	11.8RER	5.5	9.6 – 11.3	10100045	3740	35 – 40
15400028	12.0RER	6.5	9.5 – 11.5	10100047	4043	37.6 – 43
15400029	12.3RER	6.5	9.8 – 11.8	10100049	4346	40.6 – 46
15400030	12.8RER	6.5	10.3 – 12.3	2-Ear Clamps, stainless		
15400031	13.3RER	6.5	10.6 – 12.6	15100000	0041R	3.1 – 4.1
15400032	13.8RER	6.5	11.1 – 13.1	15100001	0045R	3.5 – 4.5
15400033	14.0RER	6.5	11.3 – 13.3	15100002	0305R	3.4 – 5
15400034	14.5RER	6.5	11.8 – 13.8	15100003	0507R	5 – 7
15400035	15.0RER	6.5	12.3 – 14.3	15100004	0709R	7 – 9
15400036	15.5RER	6.5	12.8 – 14.8	15100023	0811R	8 – 11
15400037	16.0RER	7	13.1 – 15.3	15100006	1113R	11 – 13
15400038	16.5RER	8	13.2 – 15.8	15100007	1315R	12.5 – 15
15400039	16.8RER	7	13.9 – 16.1	15100008	1517R	14 – 17
15400040	17.5RER	7	14.6 – 16.8	15100010	1720R	16.2 – 20
15400041	18.5RER	7	15.6 – 17.8	15100011	1922R	18.1 – 22
15400042	19.5RER	7.5	16.5 – 18.8	15100012	2023R	19.1 – 23
15400043	20.0RER	7.5	17.1 – 19.3	15100013	2225R	21.1 – 25
15400044	20.7RER	9	17.1 – 20	15100014	2327R	22.5 – 27
15400045	21.0RER	7.5	18 – 20.3	15100015	2528R	24 – 28
15400046	21.8RER	7.5	18.8 – 21.1	15100016	2731R	26.3 – 31
15400065	22.5RER	8.5	19.2 – 21.8	15100018	3134R	29.3 – 34
15400048	23.5RER	8.5	20.2 – 22.8	15100019	3437R	32 – 37
15400049	24.5RER	9	21 – 23.8	15100020	3740R	35 – 40
15400050	25.5RER	9	22 – 24.8	15100021	4043R	37.6 – 43
15400051	26.3RER	8.5	23 – 25.6	15100022	4346R	40.6 – 46
15400052	27.0RER	9.5	23.3 – 26.3			
15400053	30.7RER	11	26.5 – 30			

New Development

Next generation Stepless® Ear Clamps

Product Group 123 & 193

Stainless steel



-
- 1 Pre-closed interlock: higher radial forces, smooth outer contour
 - 2 Improved steplessness: reduced friction, continuous 360° sealing surface
-
-
-
-
-
-
-

Coated Steel



Low Profile Clamps

Stepless® Low Profile Clamps
With/without tolerance compensation
PG 168



OETIKER will be pleased to help you find the correct choice for your application. Send sample parts and all relevant information for your specific application to OETIKER, and you will receive recommendations for product type, diameter, and method of installation.

Reusability:

+ Can be repeatedly opened and re-installed

Low installed height:

+ Minimum space requirement
+ Minimal imbalance on rotating parts

Tolerance compensation:

+ Provides a degree of compensation for component tolerances*

* depending on the product type

p. 44

Stepless® Low Profile Clamps 192
PG 192

p. 48

Clamps ER
PG 194



Tolerance compensation
convolutes:

- + Allow for variations in component tolerances and temperature variations

360° Stepless®:

- + Uniform 360° compression or uniform surface pressure

Novel tensoning hook design:

- + Fast and simple installation
- + High radial forces

Compact:

- + Lightweight
- + Miniature sizes

Solid closure:

- + Fast and simple installation
- + Safe connections for low pressure applications



Reusability: can be repeatedly opened and re-installed

360° Stepless®: uniform 360° compression or uniform surface pressure

Low installed height: minimum space requirement, low imbalance on rotating parts

Load retaining hooks: visual indication that clamp is correctly installed

Specially formed edges: reduced risk of damage to parts being clamped

Stepless® Low Profile Clamps Product Group 168

Material

168 Stainless steel material No. 1.4301 or UNS S30400

Alternative materials available on request.

Series

Nominal diameter	width x thickness
10.5 – 19.0 mm	9.0 x 0.5 mm
19.5 – 110.0 mm	7.0 x 0.6 mm
25.0 – 110.0 mm	9.0 x 0.6 mm
60.0 – 120.5 mm	10.0 x 0.6 mm

Some sizes are only available if an appropriate minimum quantity is ordered.

Stepless® Low Profile Clamps are produced in several nominal widths and thicknesses. The dimensions of the material used for the standard range are determined taking into account the required radial force, the nature of the application and the need to maintain sealing and/or retaining properties under the specified conditions and environmental exposure. When selecting the clamp diameter, the dimensions of the mating components on which the clamp is to be installed must be accurately established to enable effective clamping performance. The durometer hardness of the soft material and the desired compression are important factors when calculating the appropriate clamp diameter.

Tensioning hook and tunnel

The tensioning hook and tunnel have been developed to withstand a maximum closing force of 2000 N. With the use of an OETIKER installation tool, the clamp is reduced in diameter until the interlock position is achieved. The diameter reduction of the clamp is proportional to the closing travel. The theoretical maximum reduction in diameter is given by the formula:

$$\text{Max. diameter reduction} = \frac{\text{closing travel}}{\pi}$$

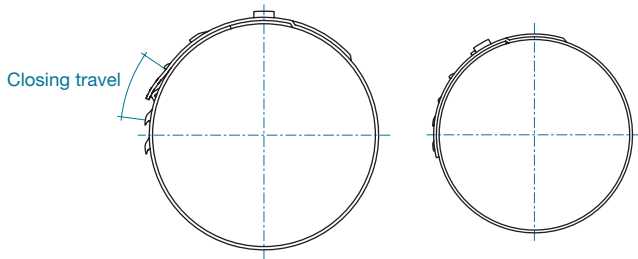

Assembly Recommendations

Using a hand tool, or a pneumatic tool specifically designed for high volume production, locate the jaw tips in the tensioning hook and tunnel.

Activating the pneumatic tool, or closing the hand tool, simultaneously draws the two features together, reducing the inside diameter of the clamp. To maintain this reduced diameter, the apertures are depressed over the load retaining hooks and the applied load exerted by the tool is released, so that the hooks engage in the appropriate apertures.

The Stepless® Low Profile Clamp provides a constant, accurate, inside diameter after installation, but, unlike Stepless® Ear Clamps PG 167, will not compensate for variations in component tolerance or accommodate the effects of thermal expansion.

The sealing pressure beneath the clamp is dependent on the compression factor established when determining the appropriate clamp diameter and the resistance to thermal “set” of the soft material.



Complete process monitoring, including 100% documentation is available using the Electronically Controlled pneumatic power tool OETIKER ELK 01.

Rotation diameter

The rotation diameter (RD) of an assembled clamp can be critical design information for applications that rotate in close proximity to adjacent components. The following list gives rotation diameters for various band sizes and product designs:

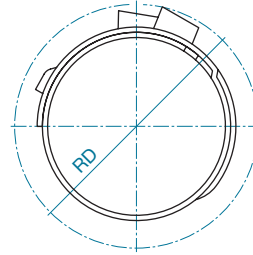

- RD for 905RWW = inside diameter +7.2 mm
- RD for 706R = inside diameter +6.0 mm
- RD for 906R = inside diameter +6.0 mm
- RD for 1006R = inside diameter +6.3 mm

Reuseability

OETIKER Stepless® Low Profile Clamps are reusable. They can be repeatedly opened and reinstalled – for example in the automotive industry at maintenance and service intervals. They can be installed both axially and radially.

Note on ordering

In contrast to ear clamps, Stepless® Low Profile Clamps are identified with the nominal closed diameter, e.g. 195 for a closed and installed diameter of 19.5 mm.

Material dimensions	Manual pincer*	Recommended pneumatic pincer**
9 x 0.5 mm	14100030	HO 3000
7 x 0.6 mm	14100030	HO 3000
9 x 0.6 mm	14100030	HO 3000
10 x 0.6 mm	14100030	HO 3000

* 14100030 Manual pincer for Stepless® Low Profile Clamps 7 mm and 10 mm wide

** With appropriate pincer head

Order information

Item No.	Ref. No.	Ø upon delivery (mm)	Ø nominal, closed (mm)	Item No.	Ref. No.	Ø upon delivery (mm)	Ø nominal, closed (mm)
Band width 9 mm, thickness 0.5 mm (905RWV)				Band width 7 mm, thickness 0.6 mm (706R)			
16800561	0105-905RWV	13.3	10.5	16800234	0360-706R	40.4	36
16800562	0110-905RWV	13.8	11	16800235	0365-706R	40.9	36.5
16800563	0115-905RWV	14.3	11.5	16800236	0370-706R	41.4	37
16800564	0120-905RWV	14.8	12	16800237	0375-706R	41.9	37.5
16800565	0125-905RWV	15.3	12.5	16800238	0380-706R	42.4	38
16800566	0130-905RWV	15.8	13	16800239	0385-706R	42.9	38.5
16800567	0135-905RWV	16.3	13.5	16800240	0390-706R	43.4	39
16800568	0140-905RWV	16.8	14	16800241	0395-706R	43.9	39.5
16800569	0145-905RWV	17.3	14.5	16800242	0400-706R	44.4	40
16800570	0150-905RWV	17.8	15	16802330	0405-706R	44.9	40.5
16800571	0155-905RWV	18.3	15.5	16800243	0410-706R	45.4	41
16800572	0160-905RWV	18.8	16	16800244	0415-706R	45.9	41.5
16800573	0165-905RWV	19.3	16.5	16800245	0420-706R	46.4	42
16800574	0170-905RWV	19.8	17	16800246	0425-706R	46.9	42.5
16802321	0175-905RWV	20.3	17.5	16800247	0430-706R	47.4	43
16800575	0180-905RWV	20.8	18	16800248	0435-706R	47.9	43.5
16803070	0185-905RWV	21.3	18.5	16800249	0440-706R	48.4	44
16800576	0190-905RWV	21.8	19	16800250	0445-706R	48.9	44.5
Band width 7 mm, thickness 0.6 mm (706R)				16800251	0450-706R	49.4	45
16800201	0195-706R	23.9	19.5	16800252	0455-706R	49.9	45.5
16800202	0200-706R	24.4	20	16800253	0460-706R	50.4	46
16800203	0205-706R	24.9	20.5	16802331	0465-706R	50.9	46.5
16800204	0210-706R	25.4	21	16802332	0470-706R	51.4	47
16800205	0215-706R	25.9	21.5	16803115	0475-706R	51.9	47.5
16800206	0220-706R	26.4	22	16800254	0480-706R	52.4	48
16800207	0225-706R	26.9	22.5	16800255	0485-706R	52.9	48.5
16800208	0230-706R	27.4	23	16800256	0490-706R	53.4	49
16800209	0235-706R	27.9	23.5	16800257	0495-706R	53.9	49.5
16800210	0240-706R	28.4	24	16800258	0500-706R	54.4	50
16800211	0245-706R	28.9	24.5	16800259	0505-706R	54.9	50.5
16800212	0250-706R	29.4	25	16800260	0510-706R	55.4	51
16800213	0255-706R	29.9	25.5	16800261	0515-706R	55.9	51.5
16800214	0260-706R	30.4	26	16800262	0520-706R	56.4	52
16800215	0265-706R	30.9	26.5	16800263	0525-706R	56.9	52.5
16800216	0270-706R	31.4	27	16800264	0530-706R	57.4	53
16800217	0275-706R	31.9	27.5	16800265	0535-706R	57.9	53.5
16800218	0280-706R	32.4	28	16800266	0540-706R	58.4	54
16800219	0285-706R	32.9	28.5	16800267	0545-706R	58.9	54.5
16800220	0290-706R	33.4	29	16800268	0550-706R	59.4	55
16800221	0295-706R	33.9	29.5	16800269	0555-706R	59.9	55.5
16800222	0300-706R	34.4	30	16800270	0560-706R	60.4	56
16800223	0305-706R	34.9	30.5	16800271	0565-706R	60.9	56.5
16800224	0310-706R	35.4	31	16800272	0570-706R	61.4	57
16800225	0315-706R	35.9	31.5	16800273	0575-706R	61.9	57.5
16800226	0320-706R	36.4	32	16800274	0580-706R	62.4	58
16800227	0325-706R	36.9	32.5	16800275	0585-706R	62.9	58.5
16800228	0330-706R	37.4	33	16800276	0590-706R	63.4	59
16800229	0335-706R	37.9	33.5	16800277	0595-706R	63.9	59.5
16800230	0340-706R	38.4	34	16800278	0600-706R	64.4	60
16800231	0345-706R	38.9	34.5	16800279	0605-706R	64.9	60.5
16800232	0350-706R	39.4	35	16800281	0610-706R	65.4	61
16800233	0355-706R	39.9	35.5	16800282	0615-706R	65.9	61.5
				16800283	0620-706R	66.4	62
				16800284	0625-706R	66.9	62.5

Order information

Item No.	Ref. No.	Ø upon delivery (mm)	Ø nominal, closed (mm)	Item No.	Ref. No.	Ø upon delivery (mm)	Ø nominal, closed (mm)
Band width 7 mm, thickness 0.6 mm (706R)				Band width 7 mm, thickness 0.6 mm (706R)			
16800285	0630-706R	67.4	63	16800339	0900-706R	94.4	90
16800286	0635-706R	67.9	63.5	16800340	0905-706R	94.9	90.5
16800287	0640-706R	68.4	64	16800341	0910-706R	95.4	91
16800288	0645-706R	68.9	64.5	16800342	0915-706R	95.9	91.5
16800289	0650-706R	69.4	65	16800343	0920-706R	96.4	92
16800290	0655-706R	69.9	65.5	16800344	0925-706R	96.9	92.5
16800291	0660-706R	70.4	66	16800345	0930-706R	97.4	93
16800292	0665-706R	70.9	66.5	16800346	0935-706R	97.9	93.5
16800293	0670-706R	71.4	67	16800347	0940-706R	98.4	94
16800294	0675-706R	71.9	67.5	16800348	0945-706R	98.9	94.5
16800295	0680-706R	72.4	68	16800349	0950-706R	99.4	95
16800296	0685-706R	72.9	68.5	16800350	0955-706R	99.9	95.5
16800297	0690-706R	73.4	69	16800351	0960-706R	100.4	96
16800298	0695-706R	73.9	69.5	16800352	0965-706R	100.9	96.5
16800299	0700-706R	74.4	70	16800353	0970-706R	101.4	97
16800300	0705-706R	74.9	70.5	16800354	0975-706R	101.9	97.5
16800301	0710-706R	75.4	71	16800355	0980-706R	102.4	98
16800302	0715-706R	75.9	71.5	16800356	0985-706R	102.9	98.5
16800303	0720-706R	76.4	72	16800357	0990-706R	103.4	99
16800304	0725-706R	76.9	72.5	16800358	0995-706R	103.9	99.5
16800305	0730-706R	77.4	73	16800359	1000-706R	104.4	100
16800306	0735-706R	77.9	73.5	16800360	1005-706R	104.9	100.5
16800307	0740-706R	78.4	74	16800361	1010-706R	105.4	101
16800308	0745-706R	78.9	74.5	16800362	1015-706R	105.9	101.5
16800309	0750-706R	79.4	75	16800363	1020-706R	106.4	102
16800310	0755-706R	79.9	75.5	16800364	1025-706R	106.9	102.5
16800311	0760-706R	80.4	76	16800365	1030-706R	107.4	103
16800312	0765-706R	80.9	76.5	16800366	1035-706R	107.9	103.5
16800313	0770-706R	81.4	77	16800367	1040-706R	108.4	104
16800314	0775-706R	81.9	77.5	16800368	1045-706R	108.9	104.5
16800315	0780-706R	82.4	78	16800369	1050-706R	109.4	105
16800316	0785-706R	82.9	78.5	16800370	1055-706R	109.9	105.5
16800317	0790-706R	83.4	79	16800371	1060-706R	110.4	106
16800318	0795-706R	83.9	79.5	16800372	1065-706R	110.9	106.5
16800319	0800-706R	84.4	80	16800373	1070-706R	111.4	107
16800320	0805-706R	84.9	80.5	16800374	1075-706R	111.9	107.5
16800321	0810-706R	85.4	81	16800375	1080-706R	112.4	108
16800322	0815-706R	85.9	81.5	16800376	1085-706R	112.9	108.5
16800323	0820-706R	86.4	82	16800377	1090-706R	113.4	109
16800324	0825-706R	86.9	82.5	16800378	1095-706R	113.9	109.5
16800325	0830-706R	87.4	83	16800379	1100-706R	114.4	110
16800326	0835-706R	87.9	83.5				
16800327	0840-706R	88.4	84	Band width 9 mm, thickness 0.6 mm (906R)			
16800328	0845-706R	88.9	84.5	In the diameter range 25 mm to 110 mm, these clamps are available in 0.5 mm steps on request.			
16800329	0850-706R	89.4	85	Band width 10 mm, thickness 0.6 mm (1006R)			
16800330	0855-706R	89.9	85.5	In the diameter range 60 mm to 120.5 mm, these clamps are available in 0.5 mm steps on request.			
16800331	0860-706R	90.4	86				
16800332	0865-706R	90.9	86.5				
16800333	0870-706R	91.4	87				
16800334	0875-706R	91.9	87.5				
16800335	0880-706R	92.4	88				
16800336	0885-706R	92.9	88.5				
16800337	0890-706R	93.4	89				
16800338	0895-706R	93.9	89.5				

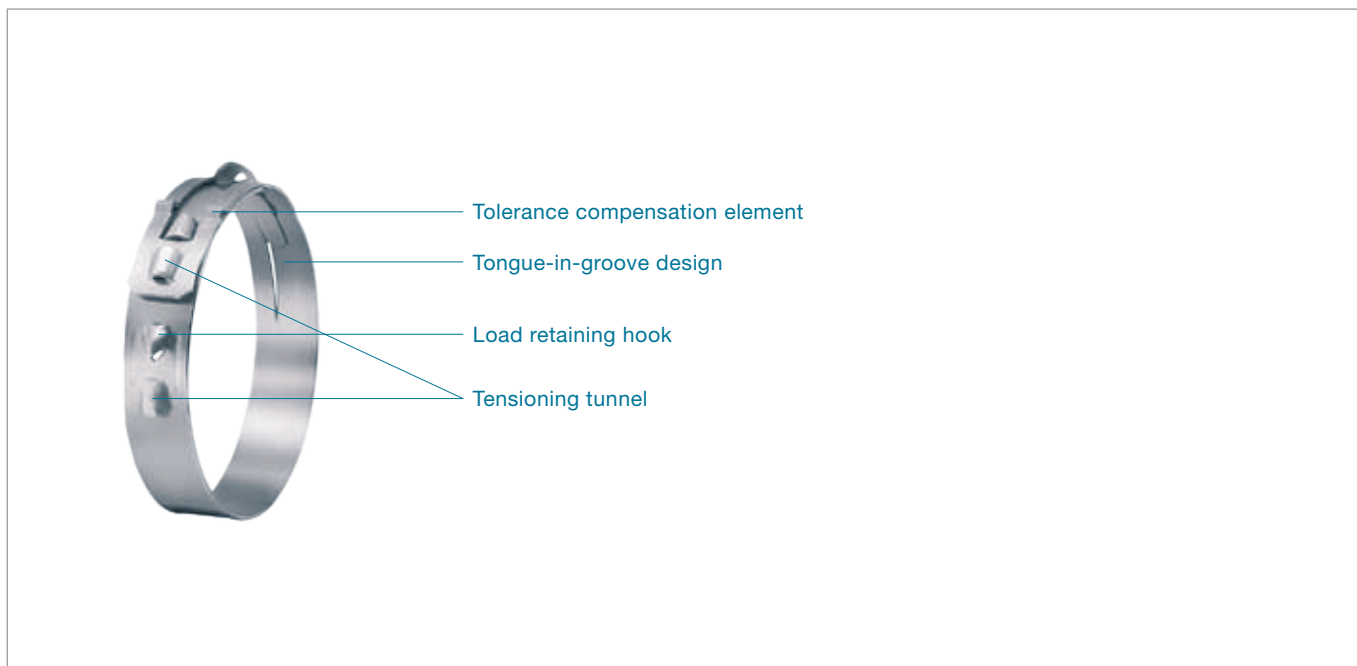

Tolerance compensation: provides a degree of compensation for component tolerances

Reusability: can be repeatedly opened and re-installed

360° Stepless®: uniform 360° compression or uniform surface pressure

Low installed height: minimum space requirement, low imbalance on rotating parts

Specially formed edges: reduced risk of damage to parts being clamped

Stepless® Low Profile Clamps with tolerance compensation, Product Group 168

Material

168 Stainless steel, material no. 1.4301/UNS S30400

Alternative materials on request.

Series

Nominal diameter	width x thickness
19.5 – 110.0 mm	9.0 x 0.6 mm

Some sizes are only available if an appropriate minimum quantity is ordered. Stepless® Low Profile Clamps with tolerance compensation are available in one standard band dimension.

When selecting the clamp diameter, the dimensions of mating components on which the clamp is to be installed must be accurately established to enable effective clamping. The durometer hardness of the soft material and desired compression are important factors when determining the appropriate clamp diameter.

Tensioning tunnels

The tensioning tunnels have been developed to withstand a maximum closing force of 2000 N. By using an OETIKER closing tool and applying it at the tensioning tunnels, the clamp is reduced in diameter until the load-retaining hook is located within the tunnel and engages with the leading edge. The diameter reduction of the clamp is proportional to the closing travel, but slightly influenced by elongation of the tolerance-compensation element under high loads. The theoretical maximum reduction in diameter is given by the formula:

$$\text{Max. diameter reduction} = \frac{\text{closing travel}}{\pi}$$

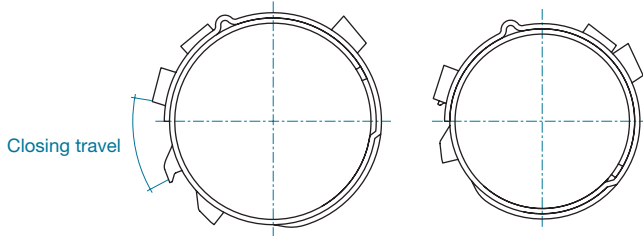

Tolerance compensation

The tolerance-compensating elements come into effect when the nominal diameter of the closed clamp cannot be achieved due to adjacent components being at the upper levels of the tolerance range. When parts being clamped have high durometer hardness values, the compensating element can be fully elongated providing the closed position is still achievable.

For optimum performance, a clamp diameter should be selected based on the theoretical lower tolerance limits of the components. Then, when the larger dimensional assembly is encountered, the tolerance compensation element is elongated to absorb the increased diameter and allow the load-retaining hook to engage in the tensioning tunnel. The application configuration, the physical properties of the materials being sealed and the required retention, are all critical factors when determining the overall functionality of the connection

Assembly Recommendations

These clamps can be closed manually using a specially developed hand tool, or a pneumatic pincer when large quantities are to be installed. To close the clamp, the tips of the pincer jaws must be inserted in the tensioning tunnel at the end of the overlap and in the tunnel next to the load-retaining hook. Operation of the closing tool reduces the diameter of the clamp to the position at which engagement of the closing hook occurs.

The design of Stepless® Low Profile Clamps with tolerance compensation is such that the inner contour of the tensioning tunnel on the end of the overlap, automatically engages with the load retaining hook when the correct position is achieved. In contrast to Stepless® low-profile clamps without tolerance compensation, they have the ability to accommodate minor variations in component tolerances during assembly and absorb diameter changes due to thermal expansion and contraction within the range of the compensating element.

As with other types of clamp, the sealing pressure beneath a clamp is a factor of the diameters and materials of the components under compression. The sealing properties of these clamps depends significantly on the opposing forces generated in the soft material of parts being secured, and the pre-loading of the tolerance-compensation element.

Complete process monitoring, including 100% documentation is available using the Electronically Controlled Pneumatic Power Tool OETIKER ELK 01.

Rotation diameter

The Stepless® Low Profile Clamp with tolerance compensation has a low radial height, and was specifically developed for applications where space is restricted, while taking into account the need to accommodate the tolerances of parts being connected.

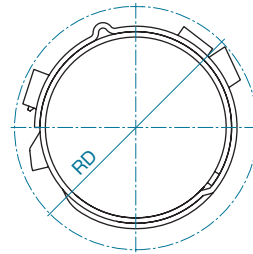

RD for 906RT8 = inside diameter +7.4 mm

Reusability

OETIKER Stepless® Low Profile Clamps with tolerance compensation are reusable to a limited extent. They can be repeatedly opened and reinstalled – for example in the automotive industry at maintenance and service intervals. They can be installed both axially and radially. To open a clamp, the pincer must be fitted to the two tunnels (1) and squeezed. The applied force has the effect of slightly reducing the diameter of the clamp, enabling the hook to disengage from the tensioning tunnel (2) on the overlapping end.

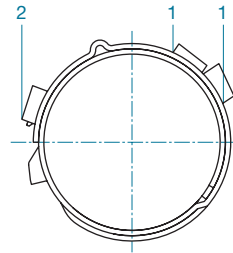

Note on ordering

In contrast to ear clamps, Stepless® Low Profile Clamps are identified with the nominal closed diameter, e.g. 195 for a closed and installed diameter of 19.5 mm.

Material dimensions	Manual pincer*	Recommended pneumatic pincer**
9 x 0.6 mm	14100109	HO 3000

* 14100109 Manual pincer for Stepless® Low Profile Clamps with tolerance compensation

** With appropriate pincer head

Order information

Item No.	Ref. No.	Ø upon delivery (mm)	Ø nominal, closed (mm)	Item No.	Ref. No.	Ø upon delivery (mm)	Ø nominal, closed (mm)
Band width 9 mm, thickness 0.6 mm (906RT8)				Band width 9 mm, thickness 0.6 mm (906RT8)			
16802113	0195-906RT8	22	19.5	16802170	0480-906RT8	50.5	48
16802114	0200-906RT8	22.5	20	16802171	0485-906RT8	51	48.5
16802115	0205-906RT8	23	20.5	16802172	0490-906RT8	51.5	49
16802116	0210-906RT8	23.5	21	16802173	0495-906RT8	52	49.5
16802117	0215-906RT8	24	21.5	16802174	0500-906RT8	52.5	50
16802118	0220-906RT8	24.5	22	16802175	0505-906RT8	53	50.5
16802119	0225-906RT8	25	22.5	16802176	0510-906RT8	53.5	51
16802120	0230-906RT8	25.5	23	16802177	0515-906RT8	54	51.5
16802121	0235-906RT8	26	23.5	16802178	0520-906RT8	54.5	52
16802122	0240-906RT8	26.5	24	16802179	0525-906RT8	55	52.5
16802123	0245-906RT8	27	24.5	16802180	0530-906RT8	55.5	53
16802124	0250-906RT8	27.5	25	16802181	0535-906RT8	56	53.5
16802125	0255-906RT8	28	25.5	16802182	0540-906RT8	56.5	54
16802126	0260-906RT8	28.5	26	16802183	0545-906RT8	57	54.5
16802127	0265-906RT8	29	26.5	16802184	0550-906RT8	57.5	55
16802128	0270-906RT8	29.5	27	16802185	0555-906RT8	58	55.5
16802129	0275-906RT8	30	27.5	16802186	0560-906RT8	58.5	56
16802130	0280-906RT8	30.5	28	16802187	0565-906RT8	59	56.5
16802131	0285-906RT8	31	28.5	16802188	0570-906RT8	59.5	57
16802132	0290-906RT8	31.5	29	16802189	0575-906RT8	60	57.5
16802133	0295-906RT8	32	29.5	16802190	0580-906RT8	60.5	58
16802134	0300-906RT8	32.5	30	16802191	0585-906RT8	61	58.5
16802135	0305-906RT8	33	30.5	16802192	0590-906RT8	61.5	59
16802136	0310-906RT8	33.5	31	16801880	0595-906RT8	62	59.5
16802137	0315-906RT8	34	31.5	16802193	0600-906RT8	62.5	60
16802138	0320-906RT8	34.5	32	16802194	0605-906RT8	63	60.5
16802139	0325-906RT8	35	32.5	16802195	0610-906RT8	63.5	61
16802140	0330-906RT8	35.5	33	16802196	0615-906RT8	64	61.5
16802141	0335-906RT8	36	33.5	16802197	0620-906RT8	64.5	62
16802142	0340-906RT8	36.5	34	16802198	0625-906RT8	65	62.5
16802143	0345-906RT8	37	34.5	16802199	0630-906RT8	65.5	63
16802144	0350-906RT8	37.5	35	16802200	0635-906RT8	66	63.5
16802145	0355-906RT8	38	35.5	16802201	0640-906RT8	66.5	64
16802146	0360-906RT8	38.5	36	16802202	0645-906RT8	67	64.5
16802147	0365-906RT8	39	36.5	16801881	0650-906RT8	67.5	65
16802148	0370-906RT8	39.5	37	16802203	0655-906RT8	68	65.5
16802149	0375-906RT8	40	37.5	16802204	0660-906RT8	68.5	66
16802150	0380-906RT8	40.5	38	16802205	0665-906RT8	69	66.5
16802151	0385-906RT8	41	38.5	16802206	0670-906RT8	69.5	67
16802152	0390-906RT8	41.5	39	16802207	0675-906RT8	70	67.5
16802153	0395-906RT8	42	39.5	16802208	0680-906RT8	70.5	68
16802154	0400-906RT8	42.5	40	16802209	0685-906RT8	71	68.5
16802155	0405-906RT8	43	40.5	16802210	0690-906RT8	71.5	69
16802156	0410-906RT8	43.5	41	16802211	0695-906RT8	72	69.5
16802157	0415-906RT8	44	41.5	16802212	0700-906RT8	72.5	70
16802158	0420-906RT8	44.5	42	16802213	0705-906RT8	73	70.5
16802159	0425-906RT8	45	42.5	16802214	0710-906RT8	73.5	71
16802160	0430-906RT8	45.5	43	16802215	0715-906RT8	74	71.5
16802161	0435-906RT8	46	43.5	16802216	0720-906RT8	74.5	72
16802162	0440-906RT8	46.5	44	16802217	0725-906RT8	75	72.5
16802163	0445-906RT8	47	44.5	16802218	0730-906RT8	75.5	73
16802164	0450-906RT8	47.5	45	16802219	0735-906RT8	76	73.5
16802165	0455-906RT8	48	45.5	16802220	0740-906RT8	76.5	74
16802166	0460-906RT8	48.5	46	16802221	0745-906RT8	77	74.5
16802167	0465-906RT8	49	46.5	16802222	0750-906RT8	77.5	75
16802168	0470-906RT8	49.5	47	16802223	0755-906RT8	78	75.5
16802169	0475-906RT8	50	47.5	16802224	0760-906RT8	78.5	76

Order information

Item No.	Ref. No.	Ø upon delivery (mm)	Ø nominal, closed (mm)	Item No.	Ref. No.	Ø upon delivery (mm)	Ø nominal, closed (mm)
Band width 9 mm, thickness 0.6 mm (906RT8)				Band width 9 mm, thickness 0.6 mm (906RT8)			
16802225	0765-906RT8	79	76.5	16803035	1050-906RT8	107.5	105
16802226	0770-906RT8	79.5	77	16803036	1055-906RT8	108	105.5
16802227	0775-906RT8	80	77.5	16803037	1060-906RT8	108.5	106
16802228	0780-906RT8	80.5	78	16803038	1065-906RT8	109	106.5
16802229	0785-906RT8	81	78.5	16802617	1070-906RT8	109.5	107
16802230	0790-906RT8	81.5	79	16803039	1075-906RT8	110	107.5
16802231	0795-906RT8	82	79.5	16803040	1080-906RT8	110.5	108
16802232	0800-906RT8	82.5	80	16803041	1085-906RT8	111	108.5
16802233	0805-906RT8	83	80.5	16803042	1090-906RT8	111.5	109
16802234	0810-906RT8	83.5	81	16803043	1095-906RT8	112	109.5
16802235	0815-906RT8	84	81.5	16803044	1100-906RT8	112.5	110
16802236	0820-906RT8	84.5	82				
16802237	0825-906RT8	85	82.5				
16802238	0830-906RT8	85.5	83				
16802239	0835-906RT8	86	83.5				
16802240	0840-906RT8	86.5	84				
16802241	0845-906RT8	87	84.5				
16802242	0850-906RT8	87.5	85				
16802243	0855-906RT8	88	85.5				
16802244	0860-906RT8	88.5	86				
16802112	0865-906RT8	89	86.5				
16802245	0870-906RT8	89.5	87				
16802246	0875-906RT8	90	87.5				
16802247	0880-906RT8	90.5	88				
16802248	0885-906RT8	91	88.5				
16802249	0890-906RT8	91.5	89				
16802250	0895-906RT8	92	89.5				
16802251	0900-906RT8	92.5	90				
16802252	0905-906RT8	93	90.5				
16802253	0910-906RT8	93.5	91				
16802254	0915-906RT8	94	91.5				
16802255	0920-906RT8	94.5	92				
16802256	0925-906RT8	95	92.5				
16802257	0930-906RT8	95.5	93				
16802258	0935-906RT8	96	93.5				
16802259	0940-906RT8	96.5	94				
16802260	0945-906RT8	97	94.5				
16802261	0950-906RT8	97.5	95				
16802262	0955-906RT8	98	95.5				
16802263	0960-906RT8	98.5	96				
16802264	0965-906RT8	99	96.5				
16802265	0970-906RT8	99.5	97				
16802266	0975-906RT8	100	97.5				
16802267	0980-906RT8	100.5	98				
16802268	0985-906RT8	101	98.5				
16802269	0990-906RT8	101.5	99				
16802270	0995-906RT8	102	99.5				
16802271	1000-906RT8	102.5	100				
16802412	1005-906RT8	103	100.5				
16802404	1010-906RT8	103.5	101				
16802418	1015-906RT8	104	101.5				
16802419	1020-906RT8	104.5	102				
16803030	1025-906RT8	105	102.5				
16803031	1030-906RT8	105.5	103				
16803032	1035-906RT8	106	103.5				
16803033	1040-906RT8	106.5	104				
16803034	1045-906RT8	107	104.5				

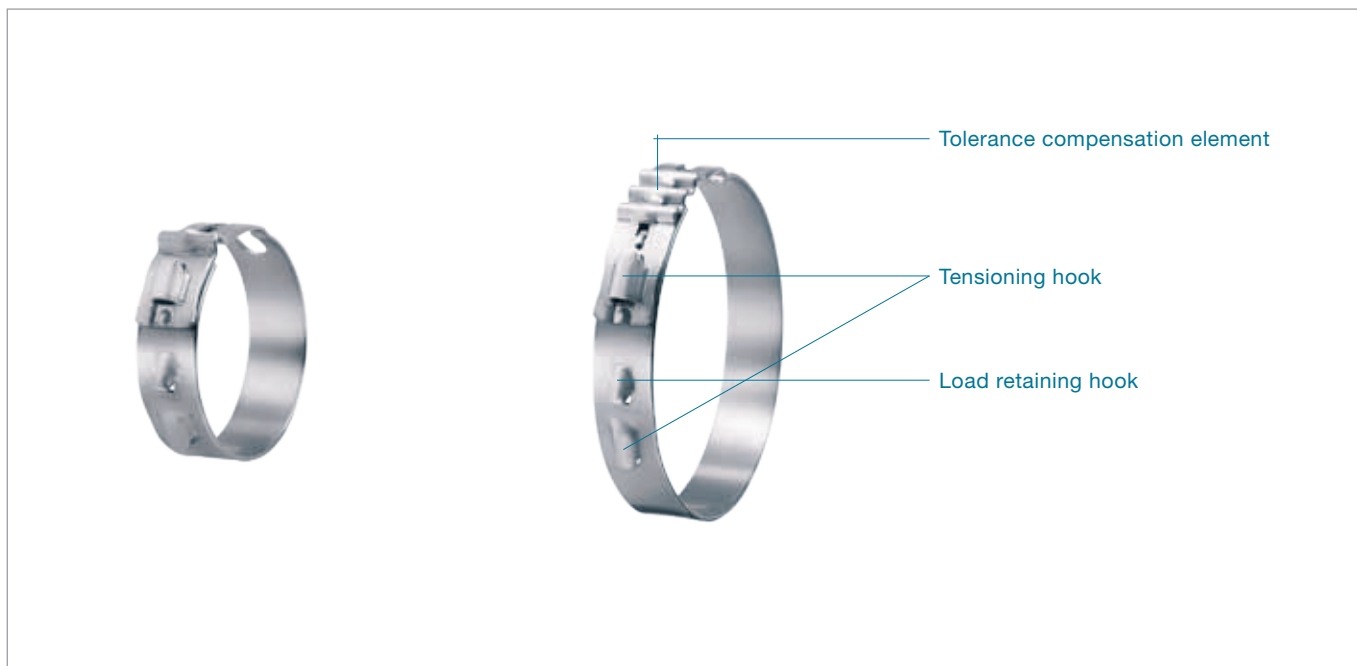

Tolerance compensation elements: allow for variations in component tolerances and temperature variations

360° Stepless®: uniform 360° compression or uniform surface pressure

Low installed height: minimum space requirement, low imbalance on rotating parts

Novel tensioning hook design: fast and simple installation, high radial force

Specially formed strip edges: reduced risk of damage to parts being clamped

Stepless® Low Profile Clamps 192 Product Group 192

Material

192 Stainless Steel, Material no. 1.4301/UNS S30400

Series

Nominal diameter	width x thickness	tol. element
19.5 – 60.0 mm	10.0 x 0.8 mm	1-wave
40.0 – 120.5 mm	10.0 x 0.8 mm	3-waves

Available in 0.5 mm diameter graduations on request.

Specific diameters can only be supplied when an appropriate minimum quantity is ordered.

OETIKER Stepless® Low Profile Clamps 192 are produced with 1-wave and 3-wave tolerance compensation elements. The dimensions of the material used within the standard range are determined taking into account the required radial force, the nature of the application and the need to maintain sealing and/or retaining properties under the specified conditions and environmental exposure. When selecting the clamp diameter, the dimensions of the mating components on which the clamp is to be installed must be accurately established to enable effective clamping performance. The durometer hardness of the soft material and desired compression are significant factors when calculating the appropriate clamp diameter.

Tensioning hooks

The tensioning hooks are the features used to close the Stepless® Low Profile Clamp 192. An OETIKER closing tool engages in both tensioning features, and tool movement reduces the clamp diameter until the internal cavity of the tensioning hook on the overlapping band fully engages in the load-retaining hook.

The diameter reduction of the clamp is substantially proportional to the closing travel, but subject to slight variations, depending on the degree to which tolerance compensation is required and the required radial force. The theoretical maximum reduction in diameter is given by the formula:

$$\text{Max. diameter reduction} = \frac{\text{closing travel}}{\pi}$$

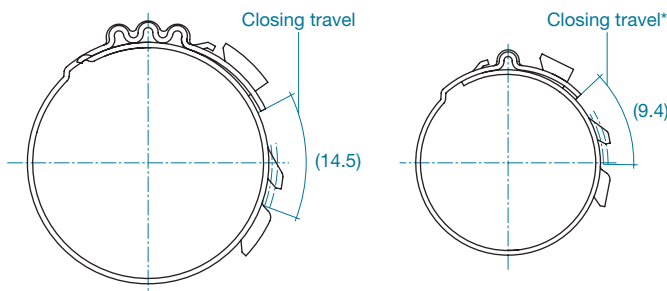

* Optionally available with enlarged as-supplied diameter (greater closing travel)

Tolerance compensation

The tolerance compensation waves are activated when the compressed diameter of the application is greater than the nominal diameter of the clamp. When the resistance against the clamp exceeds the strength of the formed convolutes, elongation occurs to enable successful engagement of the tensioning and retaining hooks.

The flexible effect of the convolutes has the potential to accommodate diameter changes due to the effects of temperature changes and vibration.

As a rule, the nominal diameter of an OETIKER Stepless® Low Profile Clamp 192 should be selected to enable the optimum hose or seal compression at the minimum assembly diameter. In the event of a maximum assembly installation, the convolutes must be capable of elongating to absorb the diameter increase while maintaining the ability to achieve the interlock engagement, taking into account the maximum permitted pincer force and the amount of elongation the convolutes can withstand.

The capability of the tolerance-compensation element, the properties and dimensional tolerance of the materials being joined all directly affect the overall functionality of the connection.

Assembly Recommendations

These clamps can be installed using manual pincers especially developed for this clamp design or, alternatively, pneumatic pincers for high volume installations. To close a clamp, the pincer jaws must be engaged within both tensioning hooks. By operating the pneumatic tool or closing the manual pincer, the simultaneous movement of the two tensioning hooks reduces the diameter of the Stepless® Low Profile Clamp 192 until the effective closed diameter is achieved. The geometry of the Stepless® Low Profile Clamp 192 is such that, on reaching this position, the internal contour of the tensioning hook on the overlapping end of the clamp engages automatically in the load retaining hook.

The surface pressure generated depends on the selection criteria, especially the diameter and materials of the parts being clamped. Sealing performance is derived mainly from the restoring force of the compressed elastic material combined with tension from the tolerance-compensation elements.

Complete process monitoring, including 100% documentation is available using the "Electronically Controlled Pneumatic Power Tool OETIKER ELK 01".

Rotation diameter

The rotation diameter (RD) of an assembled clamp can be critical design information for applications that rotate in close proximity to adjacent components.

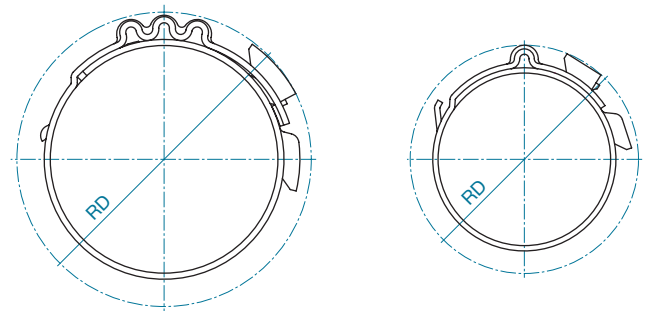

Accurate Information regarding rotation diameter can be provided on request.

Note on ordering

In contrast to ear clamps, Stepless® Low Profile Clamps are identified with the nominal closed diameter, e.g. 195 for a closed and installed diameter of 19.5 mm.

Material dimensions	Manual pincer*	Recommended pneumatic pincer**
10.0 x 0.8 mm	14100134	HO 5000 EL/HO 7000 EL

* 14100134 Manual pincer for Stepless® Low Profile Clamps 192.

** With appropriate pincer head and closing force setting.

Please provide us with appropriate sample parts and comprehensive information about the application.



Order information

Item No. Ø upon delivery (mm) Ø nominal, closed (mm)*

Item No. Ø upon delivery (mm) Ø nominal, closed (mm)*

Item No. Ø upon delivery (mm) Ø nominal, closed (mm)*

Tolerance compensation element 1-wave
Band width 10 mm, thickness 0.8 mm

Tolerance compensation element 1-wave
Band width 10 mm, thickness 0.8 mm

Tolerance compensation element 3-waves
Band width 10 mm, thickness 0.8 mm

19200686	22.5	19.5
19200684	23	20
19200685	23.5	20.5
19200688	24	21
19200733	24.5	21.5
19200734	25	22
19200244	25.5	22.5
19200245	26	23
19200255	26.5	23.5
19200263	27	24
19200368	27.5	24.5
19200369	28	25
19200370	28.5	25.5
19200371	29	26
19200372	29.5	26.5
19200253	30	27
19200322	30.5	27.5
19200373	31	28
19200374	31.5	28.5
19200268	32	29
19200375	32.5	29.5
19200376	33	30
19200377	33.5	30.5
19200378	34	31
19200379	34.5	31.5
19200380	35	32
19200381	35.5	32.5
19200333	36	33
19200335	36.5	33.5
19200382	37	34
19200383	37.5	34.5
19200332	38	35
19200384	38.5	35.5
19200385	39	36
19200386	39.5	36.5
19200358	40	37
19200387	40.5	37.5
19200388	41	38
19200389	41.5	38.5
19200390	42	39
19200391	42.5	39.5
19200392	43	40
19200393	43.5	40.5
19200394	44	41
19200395	44.5	41.5
19200396	45	42
19200397	45.5	42.5
19200398	46	43
19200399	46.5	43.5

19200400	47	44
19200401	47.5	44.5
19200402	48	45
19200403	48.5	45.5
19200404	49	46
19200405	49.5	46.5
19200406	50	47
19200407	50.5	47.5
19200408	51	48
19200409	51.5	48.5
19200410	52	49
19200411	52.5	49.5
19200412	53	50
19200413	53.5	50.5
19200414	54	51
19200415	54.5	51.5
19200416	55	52
19200417	55.5	52.5
19200418	56	53
19200419	56.5	53.5
19200420	57	54
19200421	57.5	54.5
19200422	58	55
19200423	58.5	55.5
19200424	59	56
19200425	59.5	56.5
19200426	60	57
19200427	60.5	57.5
19200428	61	58
19200429	61.5	58.5
19200430	62	59
19200431	62.5	59.5
19200432	63	60

Optionally available with enlarged as supplied diameter (greater closing travel).

19200454	44.5	40
19200455	45	40.5
19200350	45.5	41
19200352	46	41.5
19200456	46.5	42
19200457	47	42.5
19200458	47.5	43
19200459	48	43.5
19200460	48.5	44
19200461	49	44.5
19200462	49.5	45
19200463	50	45.5
19200464	50.5	46
19200465	51	46.5
19200466	51.5	47
19200467	52	47.5
19200468	52.5	48
19200469	53	48.5
19200470	53.5	49
19200471	54	49.5
19200472	54.5	50
19200473	55	50.5
19200474	55.5	51
19200339	56	51.5
19200340	56.5	52
19200475	57	52.5
19200476	57.5	53
19200477	58	53.5
19200478	58.5	54
19200479	59	54.5
19200480	59.5	55
19200481	60	55.5
19200482	60.5	56
19200483	61	56.5
19200484	61.5	57
19200485	62	57.5
19200486	62.5	58
19200487	63	58.5
19200488	63.5	59
19200489	64	59.5
19200490	64.5	60
19200491	65	60.5
19200492	65.5	61
19200493	66	61.5
19200494	66.5	62
19200495	67	62.5
19200496	67.5	63
19200341	68	63.5
19200342	68.5	64

Order information

Item No.	Ø upon delivery (mm)	Ø nominal, closed (mm)*	Item No.	Ø upon delivery (mm)	Ø nominal, closed (mm)*	Item No.	Ø upon delivery (mm)	Ø nominal, closed (mm)*
Tolerance compensation element 3-waves Band width 10 mm, thickness 0.8 mm			Tolerance compensation element 3-waves Band width 10 mm, thickness 0.8 mm			Tolerance compensation element 3-waves Band width 10 mm, thickness 0.8 mm		
19200497	69	64.5	19200546	93.5	89	19200592	118	113.5
19200498	69.5	65	19200547	94	89.5	19200593	118.5	114
19200499	70	65.5	19200548	94.5	90	19200594	119	114.5
19200500	70.5	66	19200362	95	90.5	19200595	119.5	115
19200501	71	66.5	19200549	95.5	91	19200596	120	115.5
19200502	71.5	67	19200550	96	91.5	19200597	120.5	116
19200503	72	67.5	19200551	96.5	92	19200598	121	116.5
19200504	72.5	68	19200552	97	92.5	19200599	121.5	117
19200505	73	68.5	19200553	97.5	93	19200600	122	117.5
19200506	73.5	69	19200554	98	93.5	19200601	122.5	118
19200507	74	69.5	19200555	98.5	94	19200602	123	118.5
19200508	74.5	70	19200556	99	94.5	19200603	123.5	119
19200509	75	70.5	19200557	99.5	95	19200604	124	119.5
19200510	75.5	71	19200558	100	95.5	19200605	124.5	120
19200511	76	71.5	19200559	100.5	96	19200606	125	120.5
19200512	76.5	72	19200560	101	96.5			
19200513	77	72.5	19200561	101.5	97			
19200514	77.5	73	19200562	102	97.5			
19200515	78	73.5	19200563	102.5	98			
19200516	78.5	74	19200564	103	98.5			
19200517	79	74.5	19200565	103.5	99			
19200518	79.5	75	19200566	104	99.5			
19200519	80	75.5	19200567	104.5	100			
19200520	80.5	76	19200568	105	100.5			
19200521	81	76.5	19200569	105.5	101			
19200522	81.5	77	19200570	106	101.5			
19200523	82	77.5	19200571	106.5	102			
19200524	82.5	78	19200572	107	102.5			
19200525	83	78.5	19200573	107.5	103			
19200526	83.5	79	19200343	108	103.5			
19200527	84	79.5	19200348	108.5	104			
19200528	84.5	80	19200574	109	104.5			
19200529	85	80.5	19200575	109.5	105			
19200530	85.5	81	19200576	110	105.5			
19200531	86	81.5	19200577	110.5	106			
19200532	86.5	82	19200578	111	106.5			
19200533	87	82.5	19200579	111.5	107			
19200534	87.5	83	19200580	112	107.5			
19200535	88	83.5	19200581	112.5	108			
19200536	88.5	84	19200582	113	108.5			
19200537	89	84.5	19200583	113.5	109			
19200538	89.5	85	19200584	114	109.5			
19200539	90	85.5	19200585	114.5	110			
19200540	90.5	86	19200586	115	110.5			
19200541	91	86.5	19200587	115.5	111			
19200542	91.5	87	19200588	116	111.5			
19200543	92	87.5	19200589	116.5	112			
19200544	92.5	88	19200590	117	112.5			
19200545	93	88.5	19200591	117.5	113			

* Without affecting the tolerance-compensation element (free state).

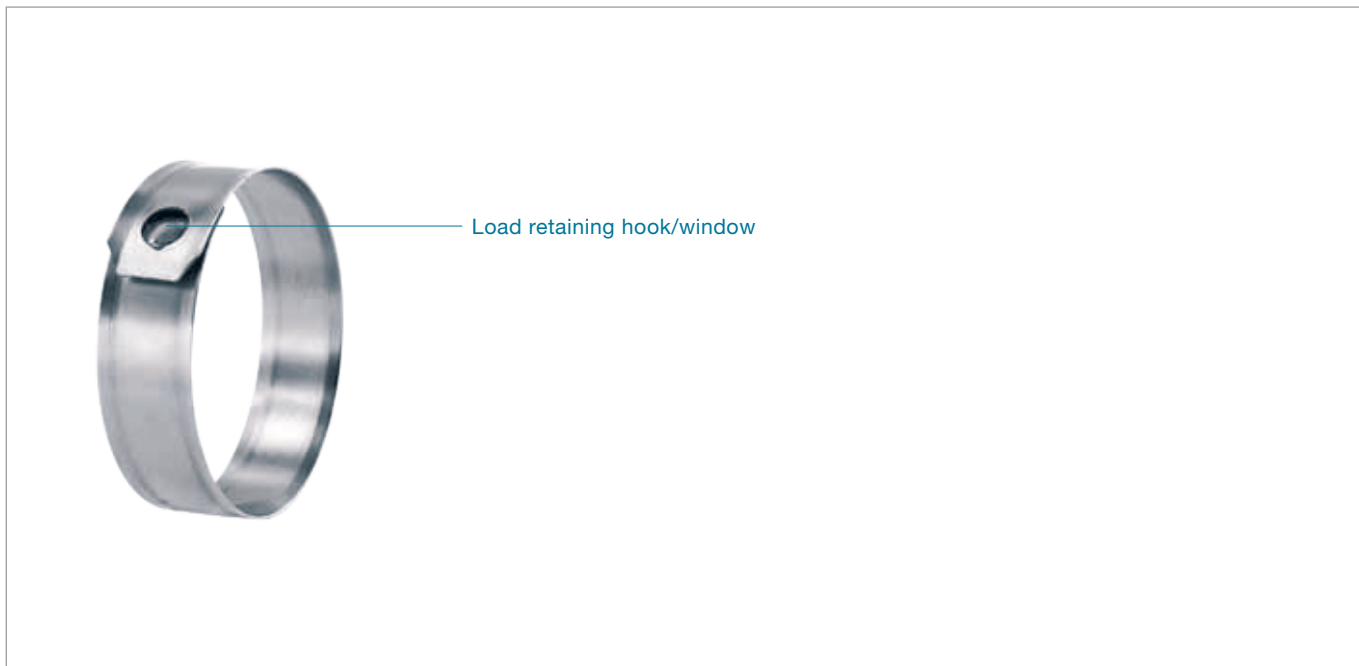

Compact: **lightweight, miniature sizes**

Low installed height: **minimum space requirement**

Solid closure: **fast and simple installation, safe connection for low pressure applications**

Specially formed strip edges: **reduced risk of damage to parts being clamped**

Clamps ER Product Group 194

Material

194 Stainless Steel, Material no. 1.4310/UNS S30100

Series

Size range	width x thickness
4.8 – ca. 25 mm	6.5 x 0.25 mm

Some sizes are only available if an appropriate minimum quantity is ordered.

OETIKER ER Clamps are made from a single, standard strip dimension. The clamp diameter must be determined very accurately to ensure correct operation in service – the required radial force, the nature of the hose and the necessary sealing and retaining properties are all extremely important.

Particular attention must be paid to the compressibility and wall-thickness of the material being joined. For assistance, please contact OETIKER.

Load retaining hook

Closure is achieved when the load retaining hook engages in the load retaining window. Both hook and window have been specially developed for this type of clamp. The reduction in diameter of the Clamp ER is proportional to the closing travel, which is approx. 4 mm. The maximum diameter reduction is thus given by the following formula:

$$\text{Max. diameter reduction} = \frac{\text{closing travel}}{\pi}$$

The very thin material, from which these clamps are made, only 0.25 mm, means that after installation there is only a very small step where the two ends of the clamp overlap. The effect of this is that the ER Clamps exert almost uniform compression, or surface pressure, on clamped parts.

The result is effective clamping of compressible materials for all manner of applications. The sealing characteristics of Clamps ER depend on the resilience provided by the compressed elastic material of the parts joined.

Assembly Recommendations

Clamps ER can be closed using a specially-developed manual pincer, or, for large quantities, using a pneumatic pincer. To install a clamp, the diameter is reduced by jaws, which completely surround it, until the load retaining hook engages in the load retaining window in the overlapping end. No specific orientation within the tool is required prior to closure.

Note on ordering

OETIKER Clamps ER are identified with the nominal closed diameter, e.g. 6 for a closed diameter of 6 mm.

Screw Clamps and Universal Clamps

p. 52

Stepless® Screw Clamp
PG 178

p. 54

ALSI Worm Drive Clamps
PG 180



OETIKER will be pleased to help you find the correct choice for your application. Send sample parts and all relevant information for your specific application to OETIKER, and you will receive recommendations for product type, diameter, and method of installation.

Choice of engagement positions:
+ Clamp can be adjusted to several different nominal diameters
360° Stepless®:
+ Uniform compression, or uniform surface pressure
Self-tensioning:
+ Compensates for thermal cycle diameter changes

Toggle lock with intermediate position:
+ Fast and simple installation
+ High tightening torque
Visual overload protection:
+ Protection against excessive tightening

p. 56

MINI Worm Drive Clamps
PG 180



Compact design:
+ Minimal space requirement
+ Miniature sizes
Embossed band:
+ Reduced risk of damage to the part being clamped

p. 58

Universal clamps
PG 174



Perforated band strip:
+ Universally applicable, various diameters and widths
Ratchet lock:
+ Installation and removal without tools
Screw lock:
+ Simple installation, high holding force

p. 62

Worm Drive Clamps
PG 126 & 177



Comply with DIN 3017:
+ Embossed clamp band
+ Large clamping range
+ High holding forces
Short housing saddle:
+ Uniform force distribution and good sealing



Choice of engagement positions: clamp can be adjusted to several different nominal diameters

Narrow Band: concentrated transmission of clamping force, complies with SAE J1508 Type SSPC

360° Stepless®: uniform compression, or uniform surface pressure.

Specially formed strip edges: reduced risk of damage to the part being clamped

Self-tensioning: compensates for thermal cycle diameter changes

Stepless® Screw Clamps Product Group 178

Material

178 Band, spacer, retaining elements (D-nut):

Stainless Steel, Material no. 1.4301/UNS S30400

Screw: Stainless Steel, Material no. 1.4319/UNS S30200

Spring: 17-7PH (aerospace quality)

Series

Size range	width x thickness
18.0 – 255.0 mm	9.0 x 0.6 mm

Some sizes are only available if an appropriate minimum quantity is ordered.

Material thickness

OETIKER Stepless® Screw Clamps and Self-Tensioning Stepless® Screw Clamps are made from strip material 9 mm wide and 0.6 mm thick. The dimensions of the strip ensure optimum sealing with EPDM rubber and silicone hoses, while taking into account the necessary radial force, the compressibility of the hose, the sealing/retaining properties and the environmental conditions.

Interlock

The closure is a mechanical interlock whose function is to provide secure retention of the round clamp geometry. The interlock can be opened to permit radial installation of the clamp, and at the same time provides a simple way of relocating the interlock features to obtain alternative diameters prior to tightening.

Positions for diameter changes

Sizes 24–42 mm

- 3 different positions
- diameter change for each step 1.6 mm

Sizes 45–55 mm

- 3 different positions
- diameter change for each step 2.1 mm

Sizes 60–255 mm

- 5 different positions
- diameter change for each step 2.0 mm

Screw: M4 x 0.7

Screw head: combination of hexagon head with cross-socket

Assembly Recommendations

1. Turn screw anti-clockwise until it stops at the “D” nut.
2. For radial installation or change of diameter, unlatch the interlock.
3. Position the open clamp around the hose. Locate the tongue in the groove and position the apertures of the mechanical interlock over the mating features. Engage the interlock at the smallest possible diameter.
4. Tighten the screw to the required torque. Do not exceed the maximum permissible tightening torque.
5. A gap of > 3 mm should exist between the D-nuts. This ensures that there is sufficient movement for the clamp to reduce in diameter when the spring of the self-tensioning clamp expands during contraction of the hose. If the gap between the D-nuts is less than the recommended 3 mm, proceed to step 6. (Only applicable to Self-Tensioning Spring Screw Clamps).
6. Turn the screw anti-clockwise to loosen the Self-Tensioning Screw Clamp.
7. Relocate the interlock in the next smaller diameter position.
8. Tighten the screw to the required torque. Do not exceed the maximum permissible tightening torque.

Maximum average, static torque guide:

Spring without colour identification (sizes 24.0–31.0 mm):

90–100 Ncm Max (8–9 inch pound-force max.)

Green spring (sizes 32.0 mm and larger):

135–200 Ncm Max (12–18 inch pound-force max.)

The values indicated above are based on maximum clamp torque capacity and common hose materials. Low durometer hardness hoses may require alternative or lower torque values and should be verified by means of product compatibility investigations.

For Stepless® Screw Clamps the minimum gap between D-nuts should be > 3mm.

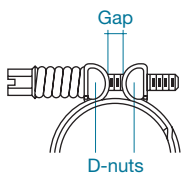

Tolerance compensation with Stepless® Screw Clamps

OETIKER Stepless® Screw Clamps and Self-Tensioning Stepless® Screw Clamps should be tightened to the optimum torque as specified in the guide. This torque takes into account the required degree of compression, the necessary radial force, and the maximum torque resistance of the screw and clamp band. By using a defined and constant torque at installation, compensation for component tolerances will always be available and the radial force will remain approximately the same.

The spring on OETIKER Self-Tensioning Stepless® Screw Clamp serves as a compensation element to accommodate changes in diameter resulting from thermal expansion and contraction or vibration. This feature gives Screw Clamps optimum sealing performance even in applications where there are strong thermal influences.

Order information

Item No.*	Ref. No.*	Item No.**	Ref. No.**	Size range (mm)
-----------	-----------	------------	------------	-----------------

Band width 9 mm, thickness 0.6 mm

17800120	024-9	17800170	024S9	18 – 24
17800122	028-9	17800172	028S9	22 – 28
17800124	032-9	17800174	032S9	26 – 32
17800125	036-9	17800175	036S9	30 – 36
17800126	040-9	17800176	040S9	34 – 40
17800127	045-9	17800177	045S9	37.5 – 45
17800128	050-9	17800178	050S9	42.5 – 50
17800129	055-9	17800179	055S9	47.5 – 55
17800130	060-9	17800180	060S9	49 – 60
17800131	065-9	17800181	065S9	54 – 65
17800132	070-9	17800182	070S9	59 – 70
17800133	075-9	17800183	075S9	64 – 75
17800134	080-9	17800184	080S9	69 – 80
17800135	085-9	17800185	085S9	74 – 85
17800136	090-9	17800186	090S9	79 – 90
17800137	095-9	17800187	095S9	84 – 95
17800138	100-9	17800188	100S9	89 – 100
17800139	105-9	17800189	105S9	94 – 105
17800140	110-9	17800190	110S9	99 – 110

* Stepless® Screw Clamps

** Self-Tensioning Screw Clamps

For Self-Tensioning Stepless® Screw Clamps, the minimum diameter of the clamping range is 1 mm larger than that given in the above table.

Alternative diameters on request.



Toggle lock with intermediate position: **fast and simple installation, high tightening torque**

Visual overload protection: **protects against excessive tightening**

Hexagon socket screw SW5: **fast and safe installation**

Alternative with wing screw: **tool integrated in the clamp**

ALSI Worm Drive Clamps Product Group 180

Material

180 W4 Band and fastener: **Stainless Steel,**

Material no. 1.4301/UNS S30400

Screw: **Stainless Steel, Material no. 1.4305/UNS S30300**

Series

Size range	width x thickness
30.0 – 500.0 mm	12.2 x 0.9 mm

Special sizes up to 1000 mm diameter available on request.

Some sizes are only available if an appropriate minimum quantity is ordered.

Screw Clamp design

Flap lock

After opening the body, the band can be formed by hand to approximately the clamping diameter. The flap can then be closed, and the clamp tightened by turning the screw. As a result, the screw only has to be turned for the last part of the clamping operation.

Intermediate stop

The flap is secured by an intermediate stop. Even when loosely installed, clamps cannot open on their own accord.

Visual overload protection

The housing incorporates a web which distorts visibly above a tightening torque of 4–5 Nm (35–44 in-lbs). This visual feature indicates that an ALSI Worm Drive Clamp is optimally tightened and still has an adequate factor of safety to the maximum tightening torque.

ALSI F with wing screw

The ALSI F Worm Drive Clamp with wing screw can be installed entirely without tools. The integral, torsionally-stiff wing provides optimum grip. Except for the wing screw, the installed dimensions are the same as those of the ALSI version.

OETIKER ALSI Universal Clamp Band

Available in 8 or 12 mm band widths in rolls of 10, 20 or 30 m band length.



Closing element for ALSI Stainless Steel Universal Clamp Band is suitable for both 8 and 12 mm band widths.

Assembly Recommendations

For safe tightening of screw clamps without wing screws, we recommend use of a 5A/F hexagon wrench. The maximum static tightening torque is 6 Nm (53 in-lb).

Installing an ALSI Universal Worm Drive Clamp

Measure the circumference to be clamped and cut off the band to that length. Pass the end of the band, from above, through the slit in the closing element, and fold it back at least 40 mm below the band. Pass the second end of the band through the slit in the perforated part of the closing element and fold it back at least 40 mm. Lay the band around the part to be clamped, push the band end with perforation below the flap lock and close.



Tighten the clamp with a 5 A/F hexagon wrench. This system may not be entirely suitable for soft and flexible components.

Order information

Item No.	Type	Clamping range D (mm)
----------	------	-----------------------

ALSI Screw Clamps

Band width 12 mm, thickness 0.9 mm

18000206	ALSI 0	30 – 60
18000069	ALSI	40 – 110
18000212	ALSI	40 – 160
18000025	ALSI 1	50 – 80
18000026	ALSI 2	80 – 110
18000027	ALSI 3	110 – 140
18000028	ALSI 4	140 – 170
18000029	ALSI 5	170 – 200
18000030	ALSI 6	200 – 230
18000031	ALSI 7	230 – 260
18000032	ALSI 8	260 – 290
18000033	ALSI 9	290 – 320
18000034	ALSI 10	320 – 350

Item No.	Description
----------	-------------

ALSI Universal Clamp Band

Band width 8 mm, thickness 0.5 mm

18000211	Closing element for ALSI stainless steel
18000213	Universal clamp band, roll 10 m long
18000214	Universal clamp band, roll 20 m long
18000215	Universal clamp band, roll 30 m long

Item No.	Type	Clamping range D (mm)
----------	------	-----------------------

ALSI F with wing screw

Band width 12 mm, thickness 0.9 mm

18000207	ALSI F 0	30 – 60
18000136	ALSI F 1	50 – 80
18000137	ALSI F 2	80 – 110
18000135	ALSI F 3	110 – 140
18000168	ALSI F 4	140 – 170
18000143	ALSI F 5	170 – 200
18000169	ALSI F 6	200 – 230
18000174	ALSI F 7	230 – 260
18000175	ALSI F 8	260 – 290
18000176	ALSI F 9	290 – 320
18000177	ALSI F 10	320 – 350

ALSI Worm Drive Clamps are available for a clamping range from 30 mm up to 1000 mm. Up to Size 5, ALSI Worm Drive Clamps are delivered pre-shaped; above Size 6 they are supplied flat. Customer-specific sizes are available on request.

Item No.	Description
----------	-------------

ALSI Universal Clamp Band

Band width 12 mm, thickness 0.5 mm

18000211	Closing element for ALSI stainless steel
18000216	Universal clamp band, roll 10 m long
18000217	Universal clamp band, roll 20 m long
18000218	Universal clamp band, roll 30 m long



Compact design: Minimal space requirement, miniature sizes

Cylindrical screw head: fast, simple and safe installation

Embossed band strip: reduced risk of damage to the part being clamped

Alternative with wing screw: tool integrated in the clamp

MINI Worm Drive Clamps Product Group 180

Material type MINI R 180

W2 Band: Rust-resistant chromium steel,

Material no. 1.4016/UNS S43000

Screw and housing: Steel, zinc-plated, blue chromate finish

Material type MINI R+S 180

W4 Band and fastener: Stainless Steel,

Material no. 1.4301/UNS S30400

Screw: Stainless Steel,

Material no. 1.4305/UNS S30300

Series

Size range	width x thickness	
7.0 – 19.0 mm	5.0 x 0.4 mm	Type R
7.0 – 219.0 mm	5.0 x 0.4 mm	Type R+S

Some sizes are only available if an appropriate minimum quantity is ordered.

Clamp Design

OETIKER MINI R+S Worm Drive Clamps

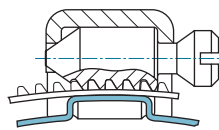

MINI R+S
Sizes 1–7 band overlapping

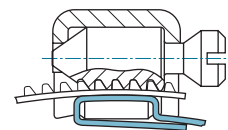

MINI R+S
Above size 8, band reverse-bent

OETIKER MINI R Worm Drive Clamps



Optionally, these clamps can be supplied open.

Assembly Recommendations

For safe tightening of screw clamps without wing screws, we recommend to use a suitable standard screwdriver.

Maximum static tightening torques:

MINI R 70 Ncm (6 in-lb)

MINI R+S/wing screw 120 Ncm (10 in-lb)

Order information

Item No.	Type	Clamping range D (mm)	Item No.	Type	Clamping range D (mm)
MINI R Worm Drive Clamp Band width 5 mm, thickness 0.4 mm			MINI R+S Worm Drive Clamps with wing screw Band width 5 mm, thickness 0.4 mm		
18000000	MINI R 1	6 – 11	18000183	MINI R+S F 1	7 – 11
18000001	MINI R 1.5	7 – 15	18000184	MINI R+S F 2	11 – 19
18000002	MINI R 2	11 – 19	18000185	MINI R+S F 3	18 – 29
18000248	MINI R 1 GZ	6 – 11	18000186	MINI R+S F 4	28 – 39
18000249	MINI R 2 GZ	9 – 19	18000187	MINI R+S F 5	38 – 49
18000252	MINI 1 S	6 – 11	18000188	MINI R+S F 6	48 – 59
18000254	MINI 2 S	11 – 19	18000189	MINI R+S F 7	58 – 69
18000255	MINI 1 GS	6 – 11	18000190	MINI R+S F 8	68 – 79
18000256	MINI 2 GS	9 – 19	18000191	MINI R+S F 9	78 – 89
GZ = rolled with cylindrical screw head			18000192	MINI R+S F 10	88 – 99
S = open with hexagon-head screw			18000193	MINI R+S F 11	98 – 109
GS = rolled with hexagon-head screw			18000194	MINI R+S F 12	108 – 119
MINI R+S Worm Drive Clamps with cylindrical screw head Band width 5 mm, thickness 0.4 mm			18000195	MINI R+S F 13	118 – 129
18000003	MINI R+S 1	7 – 11	18000196	MINI R+S F 14	128 – 139
18000004	MINI R+S 2	11 – 19	18000197	MINI R+S F 15	138 – 149
18000005	MINI R+S 3	18 – 29	18000198	MINI R+S F 16	148 – 159
18000006	MINI R+S 4	28 – 39	18000199	MINI R+S F 17	158 – 169
18000007	MINI R+S 5	38 – 49	18000200	MINI R+S F 18	168 – 179
18000008	MINI R+S 6	48 – 59	18000201	MINI R+S F 19	178 – 189
18000009	MINI R+S 7	58 – 69	18000202	MINI R+S F 20	188 – 199
18000010	MINI R+S 8	68 – 79	18000203	MINI R+S F 21	198 – 209
18000011	MINI R+S 9	78 – 89	18000204	MINI R+S F 22	208 – 219
18000012	MINI R+S 10	88 – 99			
18000013	MINI R+S 11	98 – 109			
18000014	MINI R+S 12	108 – 119			
18000015	MINI R+S 13	118 – 129			
18000016	MINI R+S 14	128 – 139			
18000017	MINI R+S 15	138 – 149			
18000018	MINI R+S 16	148 – 159			
18000019	MINI R+S 17	158 – 169			
18000020	MINI R+S 18	168 – 179			
18000021	MINI R+S 19	178 – 189			
18000022	MINI R+S 20	188 – 199			
18000023	MINI R+S 21	198 – 209			
18000024	MINI R+S 22	208 – 219			

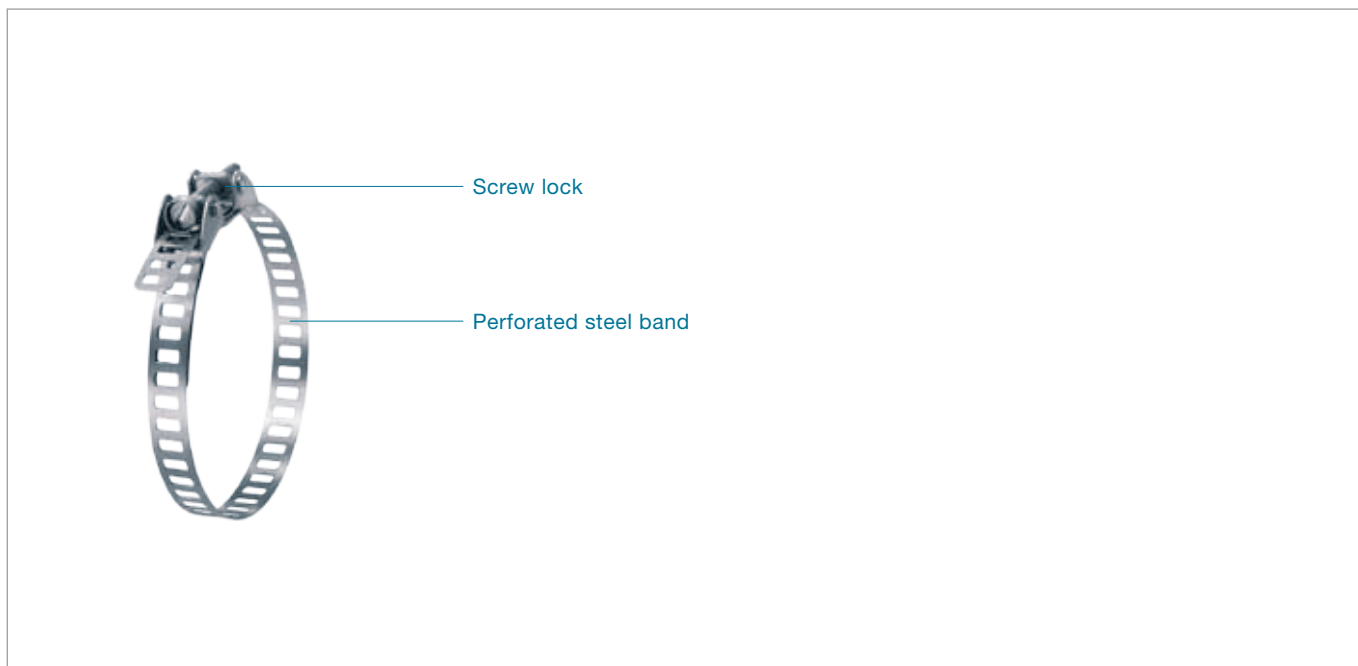

Perforated band: **universally applicable for various diameters and widths**

Ratchet lock: **installation and removal without tools**

Screw lock: **simple installation, high holding force**

Various supply options: **kit format, bulk or to customer specification**

Universal Clamps Product Group 174

Material

174 All parts are stainless steel, Material no. 1.4301/UNS S30400

Series

Size range	width x thickness
------------	-------------------

≥ 35.0 mm	10.0 x 0.5 mm
-----------	---------------

≥ 80.0 mm	18.0 x 0.8 mm*
-----------	----------------

* For use with 18 mm screw lock



Screw lock 18 mm



Ratchet lock

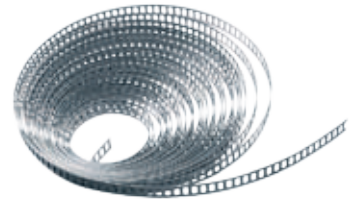

Perforated steel band

Clamp Design

Concept

Individual closure mechanism (screw or ratchet lock) combined with perforated steel band – clamps can be round or have an irregular form. Available as kits, in bulk or to customer's specification. Special versions are available with integral tolerance compensation and non-perforated band.

Universal clamps are available in standard widths and thicknesses. The band dimensions should be chosen to give the necessary radial force (clamping force) to ensure the required retention properties under the anticipated ambient conditions.

Assembly Recommendations

For installation of the Screw Lock, we recommend to use a suitable flat blade screwdriver, or a socket wrench.

Static tightening torque

Screw lock for band width 10 mm: max. 3 Nm
 Screw lock for band width 18 mm: max. 10 Nm
 Screw lock for band width 30 mm: max. 20 Nm

Assembly instructions

Screw lock type



Determine the clamp length, e.g. wrap around object to be clamped and add approx. 50 mm.



Cut off band to required length. To avoid possible injury remove sharp edges with a file and trim corners at an angle.



Insert approximately 30 mm of band material through the top of the retaining slot and fold backwards underneath the remaining strip.



Position clamp over object. Insert free end of the band over the hooks and under the screw, protruding past the body of the screw lock. Engage the hooks in the perforations at the tightest possible position.



Tighten the clamp with a screwdriver or hexagon wrench.

Ratchet lock type



Determine the clamp length, e.g. wrap around object to be clamped and add approx. 50 mm.



Cut off band to required length. To avoid possible injury remove sharp edges with a file and trim corners at an angle.



Insert approximately 30 mm of band material through the top of the retaining slot and fold backwards underneath the remaining strip.



Place lever in open position, pre-form the end of the band to match the curvature of lock. Pass free end under tongue and through slot, so that the end extends beyond the lock body.



Position clamp over object. With minimal force, press free end of band steel down and ratchet the lever back and fourth until tight. Firmly lock the lever down in the final retained position. "Securing dimple" prevents unintentional opening.

Order information

Item No.	Ref. No.	Size range (mm)	Item No.	Ref. No.	Band length (m)
Screw lock			Perforated steel band		
Compatible with band width 10 mm			Width 10 mm, material thickness 0.5 mm		
17400003	540R/10-	40 – 100	17400067	501R/10	10
17400002	540R/10+	100 – ...	17400081	501R/20	20
Compatible with band width 18 mm			Width 18 mm, material thickness 0.8 mm		
17400005	540R/18-	80 – 150	17400077	518R/10	10
17400004	540R/18+	150 – ...	17400079	518R/20	20
Ratchet lock					
Compatible with band width 10 mm					
17400063	504R/60-	35 – 60			
17400064	504R/60+	60 – ...			



Comply with DIN 3017: Embossed clamp band, large clamping range, high holding force

Short housing saddle: uniform radial load with good seal

Weld-free body connection: secure connection, good corrosion resistance

Specially formed strip edges: reduced risk of damage to parts being clamped

Worm Drive Clamps Product Group 126 & 177

Material 126

W2 Band and housing: stainless steel

Material No. 1.4016/UNS S43000

Hexagon-head screw: steel, zinc-plated

Material 177

W4 All parts: stainless steel

Material No. 1.4301/UNS S30400

Series

Diameter range	width x thickness
8.0 – 160.0 mm	9.0 x 0.6 mm
16.0 – 160.0 mm	12.0 x 0.7 mm

Other material qualities and diameter ranges on request.

Clamp design

OETIKER Worm Drive Clamps are technically advanced, multi-range hose clamps, which cover a very wide range of clamping diameters. Hoses of differing diameters can be securely connected with a single size.

Manufactured by cold-forming, the bands of these worm drive clamps have a slightly curved form. The depth of the thread impressions reduces to each side – the thread impressions have their full depth in the middle.

Worm drive clamps in material quality W2 have a 7 A/F hexagon-head screw with cross recess (Phillips). Clamps in material quality W4 have a hexagon-head screw (7 A/F) with a standard screwdriver slot.

Recommended installation

For professional installation, we recommend using a flexible screwdriver. This tool ensures safe installation even in hard-to-reach locations. For series installation requiring high process reliability, electronically monitored OETIKER controlled-torque screwdrivers should be used.

Static tightening torque:

Clamping range	B = 9	B = 12
8 – 20	2 + 0.5 Nm	
From 12 – 160	3 + 0.5 Nm	
From 16 – 160		5 + 0.5 Nm

Static test torque:

Clamping range	B = 9	B = 12
8 – 20	max. 2.6 Nm	
From 12 – 160	max. 4 Nm	
From 16 – 160		max. 6.5 Nm

Order information

Item No.	Ref. No.	Size range (mm)	Item No.	Ref. No.	Size range (mm)
----------	----------	-----------------	----------	----------	-----------------

Worm Drive Clamps W2

Band width 9 mm, thickness 0.6 mm

12600257	WD9 8-12 C7 W2	8 – 12
12600258	WD9 10-16 C7 W2	10 – 16
12600260	WD9 12-22 C7 W2	12 – 22
12600262	WD9 16-27 C7 W2	16 – 27
12600263	WD9 20-32 C7 W2	20 – 32
12600265	WD9 25-40 C7 W2	25 – 40
12600266	WD9 30-45 C7 W2	30 – 45
12600268	WD9 40-60 C7 W2	40 – 60
12600269	WD9 50-70 C7 W2	50 – 70
12600270	WD9 60-80 C7 W2	60 – 80
12600271	WD9 70-90 C7 W2	70 – 90
12600272	WD9 80-100 C7 W2	80 – 100
12600273	WD9 90-110 C7 W2	90 – 110
12600274	WD9 100-120 C7 W2	100 – 120
12600275	WD9 110-130 C7 W2	110 – 130
12600276	WD9 120-140 C7 W2	120 – 140
12600277	WD9 130-150 C7 W2	130 – 150
12600278	WD9 140-160 C7 W2	140 – 160

Worm Drive Clamps W4

Band width 9 mm, thickness 0.6 mm

17700188	WD9 8-12 C7 W4	8 – 12
17700189	WD9 10-16 C7 W4	10 – 16
17700191	WD9 12-22 C7 W4	12 – 22
17700193	WD9 16-27 C7 W4	16 – 27
17700194	WD9 20-32 C7 W4	20 – 32
17700196	WD9 25-40 C7 W4	25 – 40
17700197	WD9 30-45 C7 W4	30 – 45
17700199	WD9 40-60 C7 W4	40 – 60
17700200	WD9 50-70 C7 W4	50 – 70
17700201	WD9 60-80 C7 W4	60 – 80
17700202	WD9 70-90 C7 W4	70 – 90
17700203	WD9 80-100 C7 W4	80 – 100
17700204	WD9 90-110 C7 W4	90 – 110
17700205	WD9 100-120 C7 W4	100 – 120
17700206	WD9 110-130 C7 W4	110 – 130
17700207	WD9 120-140 C7 W4	120 – 140
17700208	WD9 130-150 C7 W4	130 – 150
17700209	WD9 140-160 C7 W4	140 – 160

Worm Drive Clamps W2

Band width 12 mm, thickness 0.7 mm

12600298	WD12 16-27 C7 W2	16 – 27
12600299	WD12 20-32 C7 W2	20 – 32
12600301	WD12 25-40 C7 W2	25 – 40
12600302	WD12 30-45 C7 W2	30 – 45
12600304	WD12 40-60 C7 W2	40 – 60
12600305	WD12 50-70 C7 W2	50 – 70
12600306	WD12 60-80 C7 W2	60 – 80
12600307	WD12 70-90 C7 W2	70 – 90
12600308	WD12 80-100 C7 W2	80 – 100
12600309	WD12 90-110 C7 W2	90 – 110
12600310	WD12 100-120 C7 W2	100 – 120
12600311	WD12 110-130 C7 W2	110 – 130
12600312	WD12 120-140 C7 W2	120 – 140
12600313	WD12 130-150 C7 W2	130 – 150
12600314	WD12 140-160 C7 W2	140 – 160

Worm Drive Clamps W4

Band width 12 mm, thickness 0.7 mm

17700229	WD12 16-27 C7 W4	16 – 27
17700230	WD12 20-32 C7 W4	20 – 32
17700232	WD12 25-40 C7 W4	25 – 40
17700233	WD12 30-45 C7 W4	30 – 45
17700235	WD12 40-60 C7 W4	40 – 60
17700236	WD12 50-70 C7 W4	50 – 70
17700237	WD12 60-80 C7 W4	60 – 80
17700238	WD12 70-90 C7 W4	70 – 90
17700239	WD12 80-100 C7 W4	80 – 100
17700240	WD12 90-110 C7 W4	90 – 110
17700241	WD12 100-120 C7 W4	100 – 120
17700242	WD12 110-130 C7 W4	110 – 130
17700243	WD12 120-140 C7 W4	120 – 140
17700244	WD12 130-150 C7 W4	130 – 150
17700245	WD12 140-160 C7 W4	140 – 160

Worm Drive Clamps W2B, W3, W5

Band width 9 mm and 12 mm

On request

p. 66

Multi Crimp Rings

MCR AL – Puzzle lock design
Aluminium
PG 150



OETIKER will be pleased to help you find the correct choice for your application. Send sample parts and all relevant information for your specific application to OETIKER, and you will receive recommendations for product type, diameter, and method of installation.

Full material cross-section over 360°:

+ Constant pressure applied uniformly around the circumference
Nominal diameter up to 120 mm:
+ Suitable for universal application, in particular for thermoplastic components

Aluminium version:

+ Reduced weight

p. 66

MCR R – spirally welded
Stainless steel
PG 150

p. 66

MCR AL – longitudinally welded
Aluminium
PG 150



Flexible diameter reduction:

- + High, adjustable surface pressure
- + Very easy to install

Low installed height:

- + Minimum space requirement
- + No imbalance on rotating parts

Nominal diameter up to 50 mm:

- + Especially suitable for cooling and heating water circuits, and for airbag systems

Flexible diameter reduction:

- + High, adjustable surface pressure
- + Very easy to install

Aluminium version – longitudinal welded:

- + Economic alternative to stainless steel

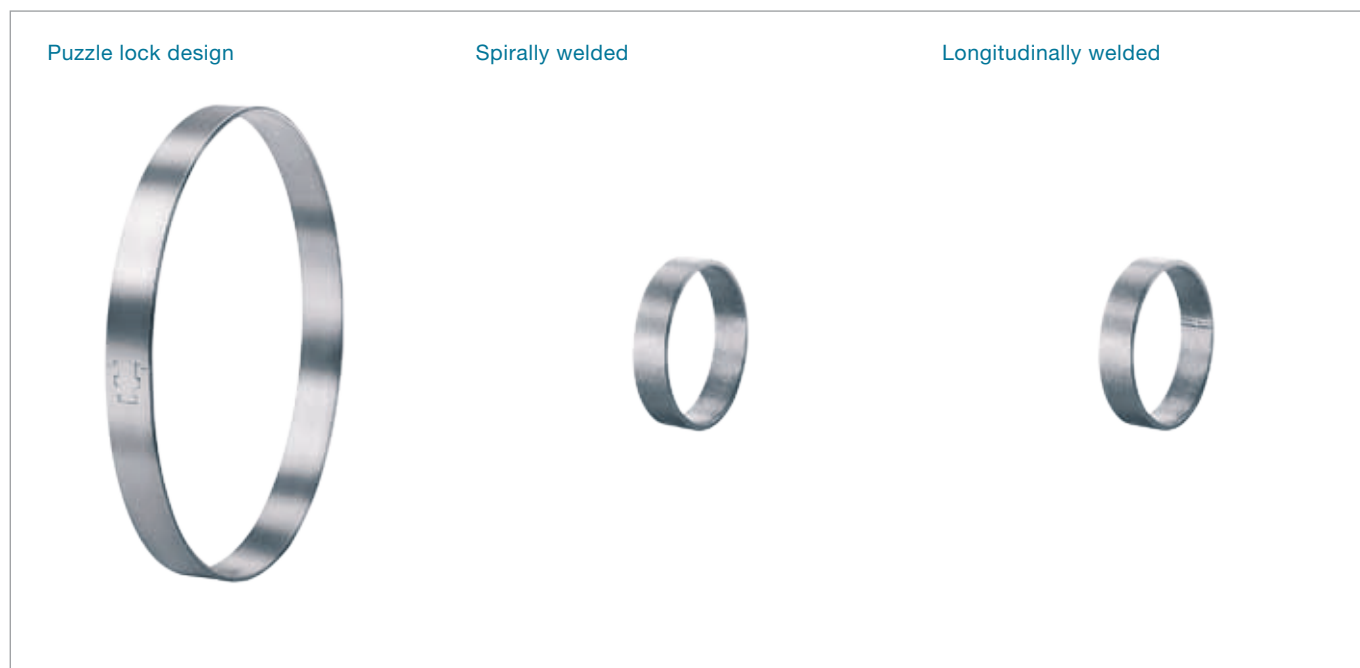

- Full material cross-section over 360°: constant pressure applied uniformly around the circumference
- Flexible diameter reduction: high, adjustable surface pressure, very easy to install
- Nominal diameter up to 120 mm: suitable for universal application, in particular for thermoplastic components
- Low installed height: minimum space requirement, no imbalance on rotating parts
- Specially formed strip edges: reduced risk of damage to parts being clamped
- Aluminium version*: reduced weight

Multi Crimp Rings Product Group 150

Materials

Puzzle lock: aluminium, Material No. 3.3535

Spirally welded: stainless steel, Material No. 1.4301/
UNS S30400

Longitudinally welded: aluminium

Range

Diameter range

5.0–120.0 mm*

* Depending on product type

Some diameters and product variants are only available if an appropriate minimum quantity is ordered.

Material dimensions

OETIKER Multi Crimp Rings are available in a range of dimensions and materials. The band dimensions should be chosen to take into account the required radial force, the nature of the hose, to ensure the necessary sealing and/or retention properties under the relevant ambient conditions, and any mechanical loads on the MCR.

Puzzle design (interlock)

The interlock is a mechanical connection employing very precise mating elements. Its design creates a positive mechanical connection. It ensures secure connection of the ring ends within the permissible load range.

OETIKER Multi Crimp Rings should be closed using the swaging tools developed and approved for them by OETIKER. The maximum practical diameter reduction depends on the diameter selected, as follows:

- MCR diameter from 27 to 40 mm
- Max. diameter reduction = 5 mm
- MCR diameter from 40.5 to 120 mm
- Max. diameter reduction = 6 mm

In the larger diameter range, the maximum diameter reduction is also restricted by the segment radii of the swaging tool. These must be chosen to correspond to the required outside diameter of the MCR after installation.

The installation process necessarily involves changes to the structure of the band material and changes in band dimensions, because the diameter reduction of an MCR is caused by the tool.

It is important to take into account that these changes become more severe the smaller the diameter of the selected MCR. The reason for this is that the quantity of material available, in effect the length of band, becomes smaller as the diameter is reduced. The band length is reduced according to the formula:

Reduction in circumference = diameter reduction $\times \pi$

For shorter installation times, easier positioning and lower stresses in the MCR material, the nominal diameter of the MCR should be as close as possible to the diameter of the part being clamped.

The required degree of compression, or the surface pressure exerted on the part being clamped by an MCR depends on the radial force which, in turn, determines the retention and sealing properties. The load on the interlock element is determined by the reaction force that counters the surface pressure. The surface pressure must be individually determined for each application.

When the specially developed OETIKER swaging tool is used, the inner surface of an MCR applies an almost completely uniform surface pressure to the part being clamped over the full 360°. The result: optimum installation and practically no out-of-balance forces from projecting parts.

Spirally welded

As an alternative to OETIKER Multi Crimp Rings with interlock, in the range 4 mm to 50 mm, OETIKER Multi Crimp Rings are available made from spirally welded stainless steel tube (Material No. 1.4301/UNS S30400).

Manufacturing process

A special feature of the manufacture of this type of MCR is the spiral rolling and welding of flat strip material to form tubes. This process was specially developed for the well-proven 1-Ear and 2-Ear Clamps from tube, and ensures the uninterrupted, robust geometry of these MCRs, known as the "One-piece Design". Flat strip material is rolled at an angle of approximately 45° into a forming die and the spiral seam of the tube so formed is TIG welded.

Subsequent calibration and cutting-off processes generate the appropriate MCR dimensions, and an abrasive barrel-finishing process eliminates burrs.

Diameter reduction

The maximum possible diameter reduction of MCRs made from tube is also diameter-dependent. It should be kept as small as possible. OETIKER will be pleased to help you find the correct choice for your specific application.

Recommendations for installing MCRs

OETIKER Multi Crimp Rings should be closed using the swaging tools developed for them. The OETIKER Swaging Tool ELS 01 offers many advantages for industrial use, for example, opening of the fixture for optimum accessibility and automatic locking, through to the electronic verification of process parameters for force-priority closure. Alternatively, conventional multi segment hydraulic and pneumatic swaging tools are commercially available.

Tolerance compensation

Tolerance compensation when installing OETIKER Multi Crimp Rings depends entirely on the function sequence of the installation tool. Fundamentally, with diameter-priority installation of OETIKER Multi Crimp Rings, tolerance compensation is impossible, because the MCR is simply closed to a specified diameter. This means that the tolerances of components exert their full effect on the degree of compression or the surface pressure applied to the part being clamped. With this type of installation, everything else is subjugated to achieving a defined diameter. Thus, tolerance compensating installation of an MCR can only be achieved with force-priority regulation. Or, to put it a different way, the basic principle here is not pressing to a given diameter, but achieving an empirically determined closing force, and so the surface pressure associated with it.

With the innovative closure concept of the "OETIKER ELS 01", high process reliability combined with the force-priority, verified installation of OETIKER Multi Crimp Rings is assured. Gauges for checking the closing force are also available.

MCR AL – longitudinally welded

On request

Samples for Special Clamps (on request)

1-Ear Clamp SV
PG 153

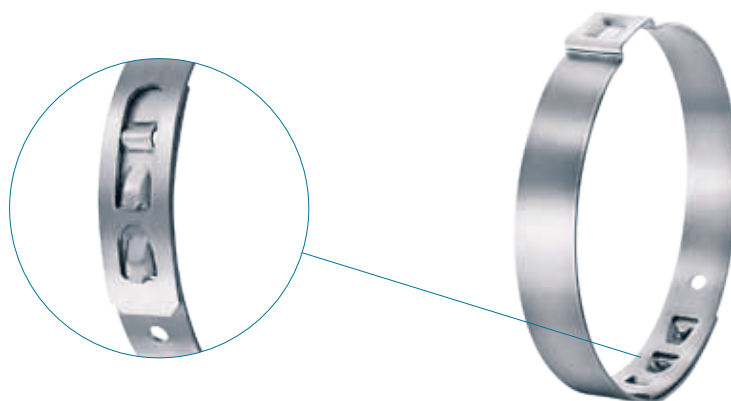

OETIKER will be pleased to help you find the correct choice for your application. Send sample parts and all relevant information for your specific application to OETIKER, and you will receive recommendations for product type, diameter, and method of installation.

Radial installation:

+ Clamp can be opened to clear obstructions for axial or radial installation

Quick closure:

+ Positive engagement of interlock ensures simple, secure closure

High-quality stainless steel:

+ High holding properties even at temperatures up to 1000°C

Flexible:

+ Can be supplied closed or pre-shaped

Applications:

Exhaust systems

Heating systems

etc.

1-Ear Clamp “Open End”
PG 195



1-Ear Clamp with stud
PG 103



1-Ear V-Profile Clamp
PG 190



Open:

+ Simple, radial installation for ergonomic handling

Flexible:

+ Customer-specific modifications are possible

Bridged ear:

+ Good sealing and excellent retention properties

Application:

Exhaust systems
Airbags
etc.

Compact:

+ Stable solutions for securing components with circular cross-sections

Flexible:

+ Customer-specific versions for form and function

Coated material:

+ High retention properties
+ good corrosion resistance

Application:

Gas generators
Sanitary pipes
Compressed air lines
etc.

V-Profile:

+ Secure and quickly installed connections

Clamp ear:

+ Compact, robust fastening
+ Tolerance compensation

Flexible:

+ Customer-specific versions for form and function

Application:

Exhaust systems
Filter units
Suction and compressed air hose (heat shields)
etc.

Quick Connectors

Thread-optimized range

Thread-optimized range
with combined release and
dust-protection sleeve



OETIKER will be pleased to help you find the correct choice for your application. The mode of operation described under Quick Connectors is the basis for further development. Connection variants and materials can be modified.

Threads and nominal bores for use where space is restricted.

Uncoupling possible with correct tool.

Simple uncoupling and provides dust protection at the same time.

Hose connection variant with integrated release and dust-protection sleeve

Length-optimized range with self-sealing taper

Thread-optimized range with integral non-return valve



Alternative connections:
Hose connection for use with clamps, Multi Crimp Rings or pressed sleeves.

Space-saving:
Thread and nominal bore increased in size so that nipple is within the connector.

Medium can flow in one direction only:
Integral non-return valve within the threaded boss

Alternative connections:
Thread sealing: The use of a taper achieves a positive, mechanical connection.



Compact: Tube end or nipple fits directly into connector

No pressure drop: In the Quick Connector, the medium does not have to change direction, and there are no restrictions

Simple connection: Quick and easy: just insert the tube or nipple – no tool needed.

Security: The groove in the tube or nipple ensures a mechanical connection

Strength: Unique design results in maximum burst pressure and retaining force

Flexible connections: machined components allow modification to meet customers' requirements

Quick Connector Product Group 200

Material

Body: Material No. 1.0737/UNS G12144

Protection against corrosion on request

Circlip: Material No 1.4310/UNS S30100

O-Ring: FPM

Other material on request

Application

OETIKER Quick Connectors are a new system for the fast, safe connection of fluid supply lines. They can be developed for specific applications and supplied in different versions to suit customers' requirements. Because they can be fitted without tools, OETIKER Quick Connectors are the optimal connector for numerous industrial applications. OETIKER Quick Connectors drastically reduce installation times. OETIKER Quick Connectors are suitable for applications that make severe demands – whether as a connection element for safety-relevant components, or for installation on oil coolers, gearboxes, turbo-units, etc.

Process monitoring

Process monitoring is carried out mechanically. With appropriate modification of the plug or tube, visual process monitoring is also possible.

Temperature range

The temperature range depends on the seal material and is defined in cooperation with the customer. O-rings in commercially available sizes are used.

Functionality



To make the connection, push the grooved tube/adaptor into the Quick Connector until it engages.



To disconnect, push the disconnection sleeve/pincer into the Quick Connector to the stop, hold it in this position, and pull out the tube/adaptor.

Operating pressure

The permissible operating pressure is directly dependent on the O-ring selected, the temperature, and the quality of the male component. It must always be determined in relation to the application.

Pull-out load on QC tube

DN8–DN18	> 6500 N
----------	----------

Cracking pressure

DN	
8	> 1100 bar
10	> 900 bar
12	> 700 bar
15	> 600 bar
18	> 400 bar

Length-optimized range

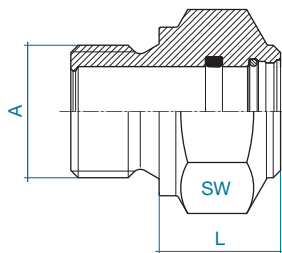

DN	A	L	SW
8	M14 x 1.5	13.9	19.0
10	M16 x 1.5	16.5	22.0
12	M18 x 1.5	16.5	24.0
15	M22 x 1.5	17.0	27.0
18	M27 x 2.0	21.5	32.0

Lengths in mm

Thread-optimized range

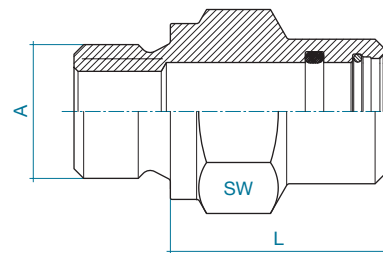

DN	A	L	SW
8	M12 x 1.5	24.5	17.0
10	M14 x 1.5	27.0	19.0
12	M16 x 1.5	28.0	22.0
15	M18 x 1.5	29.0	24.0
18	M22 x 1.5	36.4	27.0

Lengths in mm

p. 76

p. 80

Installation Tools

Test Equipment

Electronically controlled pneumatic
Pincers OETIKER ELK 01

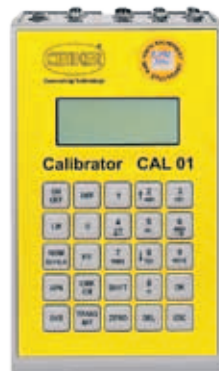

OETIKER will be pleased to help you find the correct choice for your application. Send sample parts and all relevant information for your specific application to OETIKER, and you will receive recommendations for product type, diameter, and method of installation.

Verification of closing force of installation tools

Ensures uniform, reproducible process quality

Reliable process with electronic monitoring of all specified parameters – 100% documentation

Complete integration into automated systems

Communication via PLC and PC

For universal use

p. 83

p. 92

p. 94

Pincers pneumatic + cordless

Manual closing tools

Swaging tools

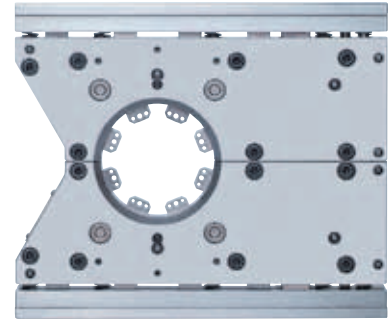

High process reliability

Efficient, uniform assembly

Cordless version for flexible use

Manual closure of clamps

Installation of Multi Crimp Rings

Separable or vertical opening for optimum component access

Intermeshing swaging segments guarantee 360° degree compression of MCR

Fast and simple exchange of swaging jaws



Ensures uniform, reproducible process quality

Provides an interface for data exchange with any OETIKER electronically controlled installation tool

AC or DC operation

Convenient carrying case

Test Equipment OETIKER CAL 01

Closing forces for OETIKER Clamps

All types of OETIKER Ear Clamps and Low Profile Clamps that can be closed using a pneumatic pincer should be closed with a recommended, uniform force. This results in a constant, reproducible tensile stress in the clamp material within the permissible limits and without overloading the individual elements of the assembly.

The “Test Equipment CAL 01” is used to adjust and verify the applied closing force. To determine the recommended closing force for a specific product, please refer to the respective clamp data.

Important

In order to ensure uniform and reproducible process quality, OETIKER recommends verifying the closing forces of installation tools daily. In addition, stable compressed air quality and volume is required. To comply with the applicable local standards for test equipment, the CAL 01 should be calibrated at least once a year by an authorized institution. Please contact OETIKER regarding this service.

Standard components included with the OETIKER
Test Equipment CAL 01

- Calibrator CAL 01 with Technical Description and Operating Instructions
- Coded load cell (SKS 01), assembled with 10 mm wide interchangeable pressure jaws (SKB 10)
- 7 mm wide pressure jaws (SKB 07)
- Calibration adaptor
- Power transformer compatible with local supply
- Data cables for communication with PC, PLC and ELK/ELS
- Lithium block battery (BAT 01)

OETIKER Test Equipment CAL 01 versions

Item No.

German	13600068
French	13600075
Dutch	13600076
Italian	13600077
Spanish	13600078
Swedish	13600079
English (UK)	13600080
English (USA)	13600081
English (Australia)	13600082
English (China)	13600155

Optional accessories and spare parts

Item No.

Mains-plug charger for block battery 9V 230V/50Hz, EURO plug	06001158
Block battery 9V	06001157
Lithium block battery 9V (BAT 01)	06001165
Mains unit 100...230V, EURO (STN 01)	06001159
Mains unit 100...230V, UK (STN 02)	06001166
Mains unit 100...230V, USA (STN 03)	06001167
Mains unit 100...230V, Australia (STN 04)	06001168
Pressure jaws SKB05 (jaw width 5 mm)	13600060
Pressure jaws SKB07 (jaw width 7 mm)	13600059
Pressure jaws SKB10 (jaw width 10 mm)	13600058
Guard* for HO2000...HO4000 (SVG01)	13600070
Guard* for HO5000/HO7000 (SVG02)	13600071

* The guards SVG01/02 surround the pincer head, and at the same time hold the SKS 01 in position so that the danger zone is protected. These guards should be used when the CAL 01 is used to carry out automatic Cmk checks



-
- Mechanical alternative for closing force calibration
 - Ensures uniform and reproducible process quality
 - Force is determined from a conversion table
 - Covers the entire standard range of closing forces
 - Provides electronic data exchange in combination with a suitable dial gauge
 - High-quality carrying case
-

Test Equipment OETIKER CAL 02

Mechanical alternative to Test Equipment CAL 01. High accuracy – especially suitable for mechanical tools.

Versions	Item No.
With MarCator 1087 dial gauge	13600243
With MarCator 1081 dial gauge	13600244
Without dial gauge	13600245

Delivery scope

- Closing force sensor (SKS 02), fitted with closing force lugs 10 mm wide (SKB 10)
 - MarCator 1087 dial gauge, electronic data transfer possible
 - MarCator 1081 dial gauge, without electronic data transfer
 - Operating instructions and accessories
-

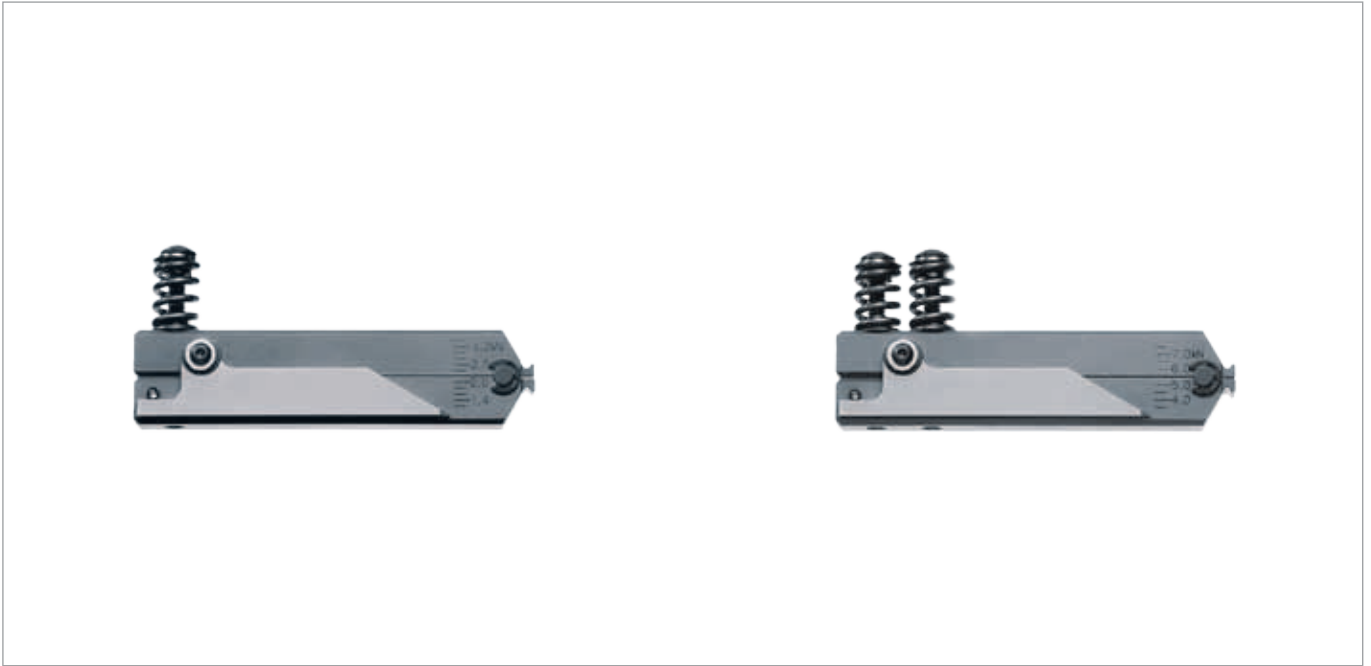

Economical alternative for closing force calibration

Force indicated by a pointer on a scale

Ensures uniform and reproducible process quality

Two models available to suit closing force range

Developed for ear clamp installation tools

Robust plastic carrying case

Test Equipment

OETIKER SKM 01 & 02

Closing Force Gauges SKM 01/02 offer economical solutions for verifying the closing forces in small series and service applications. Suitable for calibrating installation tools for ear clamps.

Types of OETIKER Closing Force Gauges	Item No.
OETIKER SKM 01	13900631
OETIKER SKM 02	13900632

Delivery scope

OETIKER SKM 01/SKM 02

– Closing Force Gauge

– Operating instructions

Technical data SKM 01

Dimensions: ca. 100 x 19.5 x 44 mm

Weight: ca. 230 g

Closing force range: 1200 N–3400 N

Graduation: 200 N

Technical data SKM 02

Dimensions: ca. 100 x 19.5 x 44 mm

Weight: ca. 240 g

Closing force range: 3500 N–7500 N

Graduation: 500 N



Control Unit

Trigger unit EL
(EL = electronic version)

Trigger unit ELT
ergonomic handling
(ELT = electronic version with
extended trigger)

Process reliability, electronic monitoring of all specified parameters – 100% documentation

Force or stroke-priority action, either with or without initial holding feature

Single, sequential or signal-controlled operation

Complete integration into automated systems

For efficient, verified assembly

Electronically Controlled Pneumatic Pincer OETIKER ELK 01

The control unit is selected by language. The pincer unit is determined by the type of OETIKER clamp to be installed, the required closing force, and the available air pressure. The pincer and control unit together form a complete unit. To obtain the optimum closing force, please refer to the technical information for the product being installed, and take into account the availability of special pincer heads.

OETIKER will be pleased to help you find the correct choice for your application. Data log acquisition from an OETIKER ELK 01, when connected to a PC, is available by installing the “CPM Clamp Process Monitoring” software – Item No. 13600121).

Standard hose/cable length of the Trigger Unit is 3 m. Alternative hose/cable lengths, also as angled versions, on request

Selection example

For a closing force of ca. 3000 N using an HO 3000 EL, the available inlet pressure must be at least 6 bar. The closing force itself must be set to the required data by changing parameters in the ELK 01 control unit. This can be done using a PC and a sequence programmed into the ELK 01, or by an external control signal. A closing force tester, for example Test Equipment CAL 01, is used to determine and set the correct closing force.

Selection of complete pincer systems

Pincer heads

Jaw width (mm)	5.5	7.5	7.5	10.2	10.2	10.2	10.5	10.5	14.5
Open gap (mm)	8.6	11.6	13.2	11.6	13.2	16.2	13.7	16.6	16.6
For ear width* (mm)	</= 7	8	10	8	10	13	10	13	13
Item No.	13900156	13900152	13900148	13900144	13900119	13900140	13900112	13900097	13900544

* measured inside

Type of pincer Standard trigger unit EL

EL
without
pincer head

HO 2000 EL										
Pincer complete	13900187	13900188	13900189	13900190	13900191	-	-	-	-	13900231
Replacement-jaw kit	13900166	13900167	13900168	13900169	13900163	-	-	-	-	
HO 3000 EL										
Pincer complete	-	13900192	13900193	13900194	13900195	13900196	-	-	-	13900232
Replacement-jaw kit	-	13900167	13900168	13900169	13900163	13900170	-	-	-	
HO 4000 EL										
Pincer complete	-	-	-	-	13900199	13900200	-	-	-	13900233
Replacement-jaw kit	-	-	-	-	13900163	13900170	-	-	-	
HO 5000 EL										
Pincer complete	-	-	-	-	-	-	13900201	13900202	-	13900234
Replacement-jaw kit	-	-	-	-	-	-	13900164	13900165	-	
HO 7000 EL										
Pincer complete	-	-	-	-	-	-	13900203	13900204	13900547	13900235
Replacement-jaw kit	-	-	-	-	-	-	13900164	13900165	13900545	
Calibration adapter**	13600016	-	-	-	-	-	-	-	-	13600016

Type of pincer Standard Trigger unit ELT with extended trigger

ELT
without
pincer head

HO 2000 ELT										
Pincer complete	13900529	13900530	13900496	13900531	13900532	-	-	-	-	13900333
Replacement-jaw kit	13900166	13900167	13900168	13900169	13900163	-	-	-	-	
HO 3000 ELT										
Pincer complete	-	13900533	13900534	13900535	13900373	13900536	-	-	-	13900335
Replacement-jaw kit	-	13900167	13900168	13900169	13900163	13900170	-	-	-	
HO 4000 ELT										
Pincer complete	-	-	-	-	13900539	13900540	-	-	-	13900337
Replacement-jaw kit	-	-	-	-	13900163	13900170	-	-	-	
HO 5000 ELT										
Pincer complete	-	-	-	-	-	-	13900525	13900526	-	13900339
Replacement-jaw kit	-	-	-	-	-	-	13900164	13900165	-	
HO 7000 ELT										
Pincer complete	-	-	-	-	-	-	13900382	13900541	13900723	13900341
Replacement-jaw kit	-	-	-	-	-	-	13900164	13900165	13900545	
Calibration adapter**	13600016	-	-	-	-	-	-	-	-	13600016

** already included in CAL 01

Item numbers in **bold type** are included in the recommended basic equipment. Replacement jaw kit = left and right pincer jaws complete with all necessary parts. The jaw width must be at least 0.5 mm wider than the band used for the clamps to be installed. The opening gap should be wide enough for the largest ear.

Control unit – numbers for languages/countries (mains plug)

D	CH	F	NL	E	I	S	UK	USA	AUS	China (E)	Japan (E)
13600219	13600230	13600220	13600223	13600222	13600221	13600224	13600225	13600226	13600227	13600228	13600229

Technical data

HO 2000 EL/HO 3000 EL/HO 4000 EL

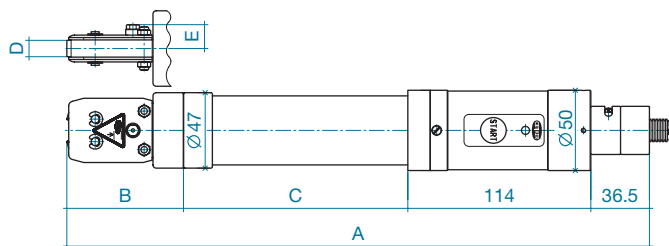

Pincer heads

Jaw width (mm)	5.5	7.5	7.5	10.2	10.2	10.2
Open gap (mm)	8.6	11.6	13.2	11.6	13.2	16.2
For ear width* (mm)	< /= 7	8	10	8	10	13
Item No.	13900156	13900152	13900148	13900144	13900119	13900140

Type of pincer

HO 2000 EL	A (mm)	325.0	324.0	324.0	324.0	324.0	-
	B (mm)	74.0	73.0	73.0	73.0	73.0	-
	C (mm)	101.0	101.0	101.0	101.0	101.0	-
	D (mm)	5.5	7.5	7.5	10.2	10.2	-
	E (mm)	12.3	13.3	13.3	14.9	14.9	-
HO 3000 EL	A (mm)	-	363.0	363.0	363.0	363.0	368.0
	B (mm)	-	73.0	73.0	73.0	73.0	78.0
	C (mm)	-	140.0	140.0	140.0	140.0	140.0
	D (mm)	-	7.5	7.5	10.2	10.2	10.2
	E (mm)	-	13.3	13.3	14.9	14.9	14.9
HO 4000 EL	A (mm)	-	-	402.0	402.0	402.0	407.0
	B (mm)	-	-	73.0	73.0	73.0	78.0
	C (mm)	-	-	179.0	179.0	179.0	179.0
	D (mm)	-	-	7.5	10.2	10.2	10.2
	E (mm)	-	-	13.3	14.9	14.9	14.9

HO 5000 EL

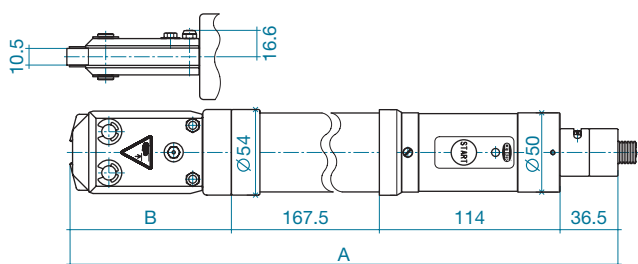

Pincer heads

Jaw width (mm)	10.5	10.5
Open gap (mm)	13.7	16.6
For ear width* (mm)	10	13
Item No.	13900112	13900097

Type of pincer

HO 5000 EL	A (mm)	420.0	425.0
	B (mm)	102.0	107.0

HO 7000 EL

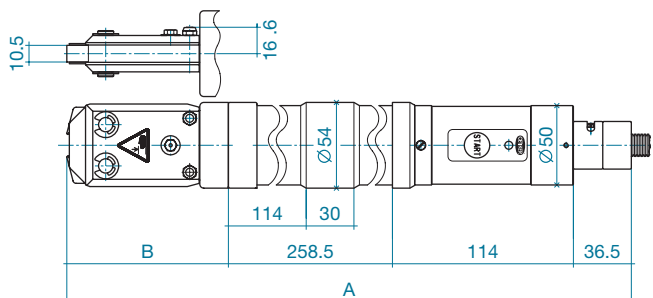

Pincer heads

Jaw width (mm)	10.5	10.5	14.5
Open gap (mm)	13.7	16.6	16.6
For ear width* (mm)	10	13	13
Item No.	13900112	13900097	13900544

Type of pincer

HO 7000 EL	A (mm)	511.0	516.0	516.0
	B (mm)	102.0	107.0	107.0

* measured inside



Installation tool with high process reliability

Efficient, uniform assembly

High-quality, complete pincer system for uniform clamp closures

Full range of pincer heads, for compatibility to all standard clamps

Adaptation of special head designs possible

Pneumatic Pincers OETIKER ME

This high-quality, complete pincer system ensures the uniform installation of OETIKER clamps. The selection of the correct pincer body and head is dependent on the type of OETIKER clamp, the required closing force, and the air supply pressure that is available.

To obtain the optimum closing force, please refer to the technical information for the product being installed, and take into account the availability of special pincer heads.

Selection example

For a closing force of ca. 3000 N using an HO 3000 ME, the available inlet pressure must be at least 5-6 bar. The closing force must be set to the data given. To change the closing force, the inlet pressure must be adjusted. A closing force tester, for example Test Equipment CAL 01, is used to determine and set the correct closing force.

Selection of complete pincer systems

Pincer heads

Jaw width (mm)	5.5	7.5	7.5	10.2	10.2	10.2	10.5	10.5	14.5
Open gap (mm)	8.6	11.6	13.2	11.6	13.2	16.2	13.7	16.6	16.6
For ear width* (mm)	</= 7	8	10	8	10	13	10	13	13
Item No.	13900158	13900154	13900150	13900146	13900138	13900142	13900113	13900114	13900543

Type of pincer

ME
without
pincer head

HO 2000 ME

Pincer complete**	13900173	13900174	13900176	13900179	13900182	-	-	-	-	13900226
Pincer complete***	13900607	13900608	13900609	13900610	13900611	-	-	-	-	13900612
Replacement-jaw kit	13900166	13900167	13900168	13900169	13900163	-	-	-	-	

HO 3000 ME

Pincer complete**	-	13900175	13900177	13900180	13900183	13900185	-	-	-	13900227
Pincer complete***	-	13900613	13900614	13900615	13900616	13900617	-	-	-	13900618
Replacement-jaw kit	-	13900167	13900168	13900169	13900163	13900170	-	-	-	

HO 4000 ME

Pincer complete**	-	-	-	-	13900184	13900186	-	-	-	13900228
Pincer complete***	-	-	-	-	13900619	13900620	-	-	-	13900621
Replacement-jaw kit	-	-	-	-	13900163	13900170	-	-	-	

HO 5000 ME

Pincer complete**	-	-	-	-	-	-	13900161	13900162	-	13900229
Pincer complete***	-	-	-	-	-	-	13900622	13900623	-	13900624
Replacement-jaw kit	-	-	-	-	-	-	13900164	13900165	-	

HO 7000 ME

Pincer complete**	-	-	-	-	-	-	13900171	13900172	13900546	13900230
Pincer complete***	-	-	-	-	-	-	13900625	13900626	13900726	13900627
Replacement-jaw kit	-	-	-	-	-	-	13900164	13900165	13900545	

* measured inside

** Swing Coupling thread G 1/4 (European)

*** Swing Coupling thread NPT 1/4 (North American)

Item numbers in **bold type** are included in the recommended basic equipment. Replacement jaw kit = left and right pincer jaws complete with all necessary parts. The jaw width must be at least 0.5 mm wider than the band used for the clamps to be installed. The opening gap should be wide enough for the largest ear.

Technical data

HO 2000 ME/HO 3000 ME/HO 4000 ME

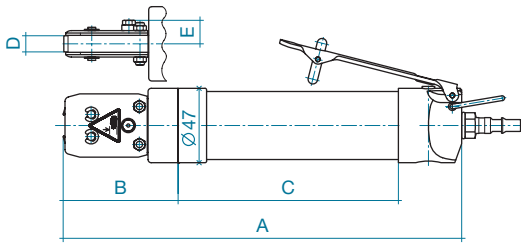

Pincer heads

Jaw width (mm)	5.5	7.5	7.5	10.2	10.2	10.2
Open gap (mm)	8.6	11.6	13.2	11.6	13.2	16.2
For ear width* (mm)	< / = 7	8	10	8	10	13
Item No.	13900158	13900154	13900150	13900146	13900138	13900142

Type of pincer

HO 2000 ME	A (mm)	214.0	213.0	213.0	213.0	213.0	-
	B (mm)	74.0	73.0	73.0	73.0	73.0	-
	C (mm)	101.0	101.0	101.0	101.0	101.0	-
	D (mm)	5.5	7.5	7.5	10.2	10.2	-
	E (mm)	12.3	13.3	13.3	14.9	14.9	-
HO 3000 ME	A (mm)	-	252.0	252.0	252.0	252.0	257.0
	B (mm)	-	73.0	73.0	73.0	73.0	78.0
	C (mm)	-	140.0	140.0	140.0	140.0	140.0
	D (mm)	-	7.5	7.5	10.2	10.2	10.2
	E (mm)	-	13.3	13.3	14.9	14.9	14.9
HO 4000 ME	A (mm)	-	-	291.0	291.0	291.0	296.0
	B (mm)	-	-	73.0	73.0	73.0	78.0
	C (mm)	-	-	179.0	179.0	179.0	179.0
	D (mm)	-	-	7.5	10.2	10.2	10.2
	E (mm)	-	-	13.3	14.9	14.9	14.9

HO 5000 ME

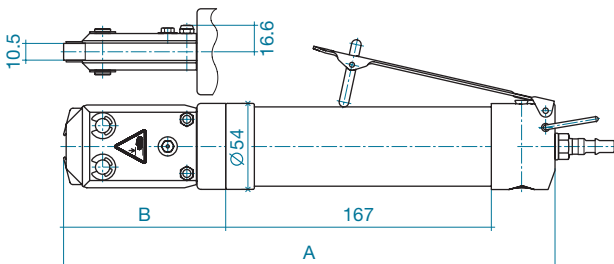

Pincer heads

Jaw width (mm)	10.5	10.5	14.5
Open gap (mm)	13.7	16.6	16.6
For ear width* (mm)	10	13	13
Item No.	13900113	13900114	13900543

Type of pincer

HO 5000 ME	A (mm)	309.0	314.0	314.0
	B (mm)	102.0	107.0	107.0

HO 7000 ME

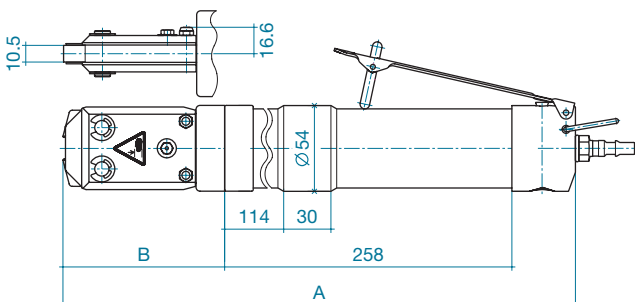

Pincer heads

Jaw width (mm)	10.5	10.5
Open gap (mm)	13.7	16.6
For ear width* (mm)	10	13
Item No.	13900113	13900114

Type of pincer

HO 7000 ME	A (mm)	400.0	405.0
	B (mm)	102.0	107.0

* measured inside

Special Pincer Heads for Pneumatic Pincers OETIKER ME/EL

For the installation of OETIKER Ear Clamps

Pincer head with extended holders

With either a 34.5 or an 80 mm extension length, these are used to make it easier to reach the clamp where access is restricted. Compatible with pincer types HO 2000 to HO 4000.

Extension 34.5 mm

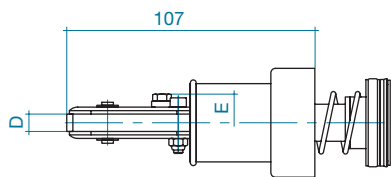

Extension 80 mm

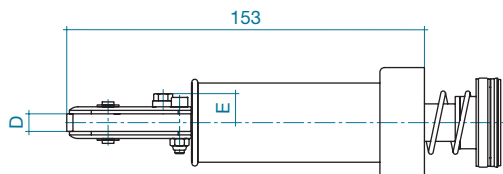

Selection of pincer heads

The jaw width must be at least 0.5 mm wider than the band used for the clamps to be installed. The opening gap should be wide enough for the largest ear.

Pincer heads

Jaw width D (mm)	5.5	7.5	10.2
Open gap (mm)	8.6	13.2	13.2
Height E (mm)	11.0	12.0	14.0
For ear width* (mm)	</=7	10	10

Type of pincer

HO ME	Pincer head complete	13900272	13900274	13900276
	Replacement-jaw kit	13900166	13900168	13900163
HO EL	Pincer head complete	13900271	13900273	13900275
	Replacement-jaw kit	13900166	13900168	13900163
	Calibration adaptor**	13600016	13600016	13600016

Pincer heads

Jaw width D (mm)	5.5	7.5	10.2
Open gap (mm)	8.6	13.2	13.2
Height E (mm)	11.0	12.0	14.0
For ear width* (mm)	</=7	10	10

Type of pincer

HO ME	Pincer head complete	13900278	13900280	13900282
	Replacement-jaw kit	13900166	13900168	13900163
HO EL	Pincer head complete	13900277	13900279	13900281
	Replacement-jaw kit	13900166	13900168	13900163
	Calibration adaptor**	13600016	13600016	13600016

* Measured inside

** already included in CAL 01

Special Pincer Heads for Pneumatic Pincers OETIKER ME

For the installation of OETIKER Ear Clamps

Pincer heads with angled jaws

Specially for installing ear clamps where access is restricted.

Suitable for ear clamps with 7 and 9 mm band widths. Compatible with pincer types HO 2000 to HO 4000.

Jaws angled at 30°

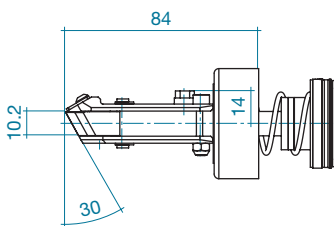

Pincer heads 30°

Jaw width (mm)	10.2
Open gap (mm)	13.2
For ear width* (mm)	10

Type of pincer

HO ME Pincer head complete	13900706
HO EL Pincer head complete	13900707
Replacement-jaw kit	13900708
Calibration set	13900722

Jaws angled at 60°

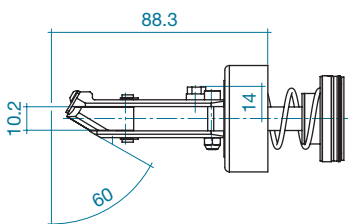

Pincer heads 60°

Jaw width (mm)	10.2
Open gap (mm)	13.2
For ear width* (mm)	10

Type of pincer

HO ME Pincer head complete	13900694
HO EL Pincer head complete	13900697
Replacement-jaw kit	13900695
Calibration set	13900696

* Measured inside

Special Pincer Heads for Pneumatic Pincers OETIKER ME/EL

For the installation of OETIKER Stepless® Low Profile Clamps

All OETIKER Stepless® Low Profile Clamps have unique head requirements and are specific to the product group designation and type.

When using OETIKER ME pneumatic pincers, it is essential to use a throttle valve for adjusting the closing speed.

OETIKER recommends the use of appropriate calibration equipment and techniques to ensure that the closing force is achieved. When used in conjunction with the HO EL body assembly, the force and closed gap can be controlled and monitored.

Pincer heads for installing reusable Stepless® Low Profile Clamps – Product Group 168 (RWV)

The hold-down springs fitted to both jaws make closure easier and improve handling. Compatible with pincer types HO 2000 to HO 4000.

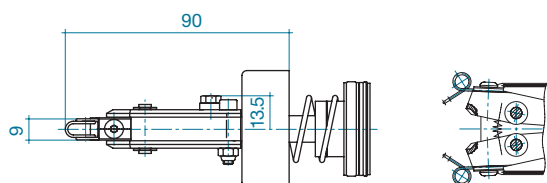

Pincer heads

Jaw width (mm)	9.0
----------------	-----

Pincer types

HO ME	Pincer head complete	13900257
	Replacement-jaw kit	13900295
	Spring accessory	13900302
	Calibration adaptor	13900590
HO EL	Pincer head complete	13900634
	Replacement-jaw kit	13900295
	Spring accessory	13900302
	Calibration adaptor	13900590

Pincer heads for installing Stepless® Low Profile Clamps – Product Group 168

The optional hold-down springs improve handling, especially for production-line applications. Can be used for standard clamps from 40 mm (or approx. 19.5 mm for special types). Can be used for clamps 7, 9 mm and 10 mm wide. Compatible with pincer types HO 3000 and HO 4000.

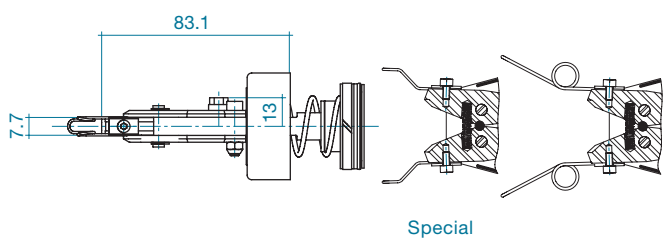

Pincer heads

	Standard	Special*
Jaw width (mm)	7.7	7.7

Pincer types

HO ME	Pincer head complete	13900664	13900666
	Replacement-jaw kit	13900673	13900673
	Spring accessory	13900675	13900676
	Calibration adaptor	13900590	13900590
HO EL	Pincer head complete	13900663	13900665
	Replacement-jaw kit	13900673	13900673
	Spring accessory	13900675	13900676
	Calibration adaptor	13900590	13900590

* Low-profile clamp with single closure hook – only for 7 mm band width. Especially suitable for small low-profile clamps

Pincer heads for installing Stepless® Low Profile Clamps with tolerance compensation – Product Group 168

Compatible with pincer types HO 3000 and HO 4000.

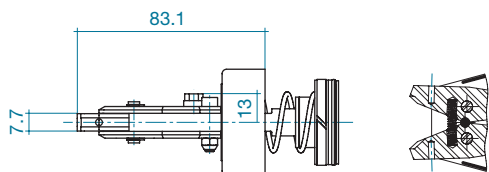

Pincer heads

	RT 8	RT 13
Jaw width (mm)	7.7	7.7

Pincer types

HO ME	Pincer head complete	13900670	13900672
	Replacement-jaw kit	13900673	13900674
	Calibration adaptor	13900590	13900590
HO EL	Pincer head complete	13900669	13900671
	Replacement-jaw kit	13900673	13900674
	Calibration adaptor	13900590	13900590

Pincer head for installing Stepless® Low Profile Clamps with tolerance compensation Type 3 Heavy Duty – Product Group 168
The hold-down spring is fitted to one jaw to assure effective interlock engagement. Compatible with pincer types HO 5000 and HO 7000.

Before deciding to use these special clamps and selecting the appropriate installation tool, please consult OETIKER

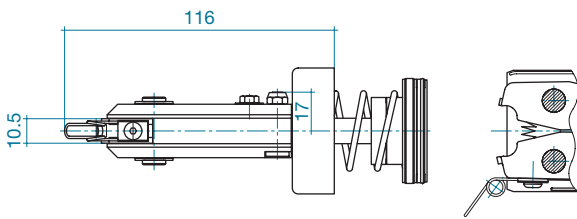

Pincer heads

Jaw width (mm)	10.5
----------------	------

Pincer types

HO ME	Pincer head complete	13900553
	Replacement-jaw kit	13900554
	Spring accessory	13900305
	Calibration adaptor ME	13900306
HO EL	Pincer head complete	13900553
	Replacement-jaw kit	13900554
	Spring accessory	13900305
	Calibration adaptor EL	13900307

Pincer head for installing Stepless® Low Profile Clamp 192 – Product Group 192

Compatible with pincer types HO 5000 EL and HO 7000 EL.

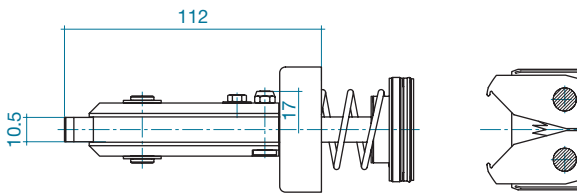

Stepless® Low Profile Clamp 192
with tolerance compensation element

Pincer heads	1/3 waves
Jaw width (mm)	10.5

Pincer types

HO EL	Pincer head complete	13900555
	Replacement-jaw kit	13900556
	Calibration adaptor EL	13900495

Pincer head for installing Clamps ER – Product Group 194
Compatible with pincer types HO 2000–4000.

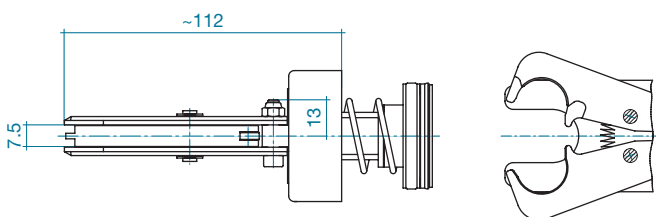

Pincer heads

Jaw width (mm)	10.5
----------------	------

Pincer types

HO ME/EL	On request
----------	------------



Efficient, uniform and repeatable assembly

Cordless installation tool for Ear Clamps

Lightweight, ergonomic design for easy handling

LED-display to indicate battery capacity and service interval

Cordless Clamp Pincer OETIKER CP 01 & 02 & 03

The Cordless Clamp Pincers CP 01, CP 02 and CP 03 are available as alternatives to the Pneumatic Pincers OETIKER ME. These devices offer good accuracy and ergonomic handling for fast, uniform assembly of OETIKER ear clamp types. The advantage of these closing tools is the cordless design and hence unrestricted, free motion during clamp assembly.

The hydraulic accumulator unit incorporates an automatic retraction function which returns the jaws to their open position when the selected maximum closing force is reached. The unit is also equipped with a special brake which stops jaw closure when the trigger is released.

The pincer head can be smoothly rotated 360° around the longitudinal axis in order to gain better access to tight corners and other hard-to-reach areas.

Delivery scope OETIKER CP 01 & 02 & 03

- Cordless Clamp Pincer complete with pincer head and accumulator
- Special screwdriver (to adjust closing force)
- Operating Instructions (multi-lingual document)
- Charger (compatible with local electrical supply voltage/ plug configuration)
- Carrying case

Optional accessories and spare parts

- Accumulator for CP 01/CP 02/CP 03 Item No.: 14000972
- Screwdriver Item No.: 14000973

Technical Data*	CP 01	CP 02	CP 03
Closing force range:	1000 N–4200 N**	4200 N–8500 N**	4500 N–9000 N*
External dimensions:	410 x 56 x 80 mm	445 x 56 x 80 mm	445 x 56 x 80 mm
Weight:	2050 g (4.5 lbs)	2250 g (5.0 lbs)	2300 g (5.0 lbs)
Closing time:	2 seconds	2 seconds	2 seconds

* Approx. data

** Closing force, depending on pincer head, can be determined via:

- CAL 01, only with Software Generation V2.2 or higher
- SKM 01 or SKM 02

Pincer heads	CP 01	CP 01	CP 02	CP 02	CP 03
Jaw width (mm)	7.5	10.2	10.5	10.5	14.5
Open gap (mm)	13.2	13.2	13.7	16.6	16.6
For ear width* (mm)	10	10	10	13	13
Item No.	13900683	13900659	13900662	13900660	13900711

Selection of pincer type according to language/country (mains plug)

CP set without pincer head

CP 01 (AUS)	-	13900651	-	-	-	13900698
Jaw replacement kit		13900163				
CP 01 (EU)	-	13900650	-	-	-	13900699
Jaw replacement kit		13900163				
CP 01 (UK)	-	13900653	-	-	-	13900700
Jaw replacement kit		13900163				
CP 01 (US)	-	13900652	-	-	-	13900701
Jaw replacement kit		13900163				
CP 02 (AUS)	-	-	13900655	-	-	13900702
Jaw replacement kit			13900164			
CP 02 (EU)	-	-	13900654	-	-	13900703
Jaw replacement kit			13900164			
CP 02 (UK)	-	-	13900657	-	-	13900704
Jaw replacement kit			13900164			
CP 02 (US)	-	-	13900656	-	-	13900705
Jaw replacement kit			13900164			
CP 03 (AUS)	-	-	-	-	13900713	13900717
Jaw replacement kit					13900545	
CO 03 (EU)	-	-	-	-	13900712	13900716
Jaw replacement kit					13900545	
CP 03 (UK)	-	-	-	-	13900715	13900719
Jaw replacement kit					13900545	
CP 03 (US)	-	-	-	-	13900714	13900718
Jaw replacement kit					13900545	

Special pincer heads	30°	60°
Jaw width (mm)	10.2	10.2
Open gap (mm)	13.2	13.2
For ear width* (mm)	10	10
Item No.	13900724	13900690

* Measured inside

Manual closing tools



Tool type	Item No.
For Ear Clamps Standard pincers with straight jaws	14100082
For Ear Clamps Pincers with side jaws for limited space	14100083
For Ear Clamps Pincers with narrow jaws for limited space	14100037
For Ear Clamps Manual pincer with force monitoring, OETIKER HMK 01. For correct installation and uniform closure. A vibration signal indicates when the preset force is reached.	On request
For Stepless Low Profile Clamps 192 Clamp pincers with special jaw form	14100134



Tool type	Item No.
For Stepless Low Profile Clamps	
Pincers with return spring	
5 mm wide	14100031
7/10 mm wide	14100030
With tolerance compensation	14100109

For Clamps ER	
Pincers with return spring	On request

For Screw Clamps/Worm Drive Clamps	
Torque wrench with digital display 1.0–5.0 Nm	14100304
Socket set bit for slotted-head screws	14100306
Socket set bit for hexagon-head screws (SW 6)	14100310
Socket set bit for hexagon-head screws (SW 7)	14100311

Torque wrench with digital display 3.2–16 Nm	14100307
Socket set bit for hexagon-head screws (SW 7)	14100308

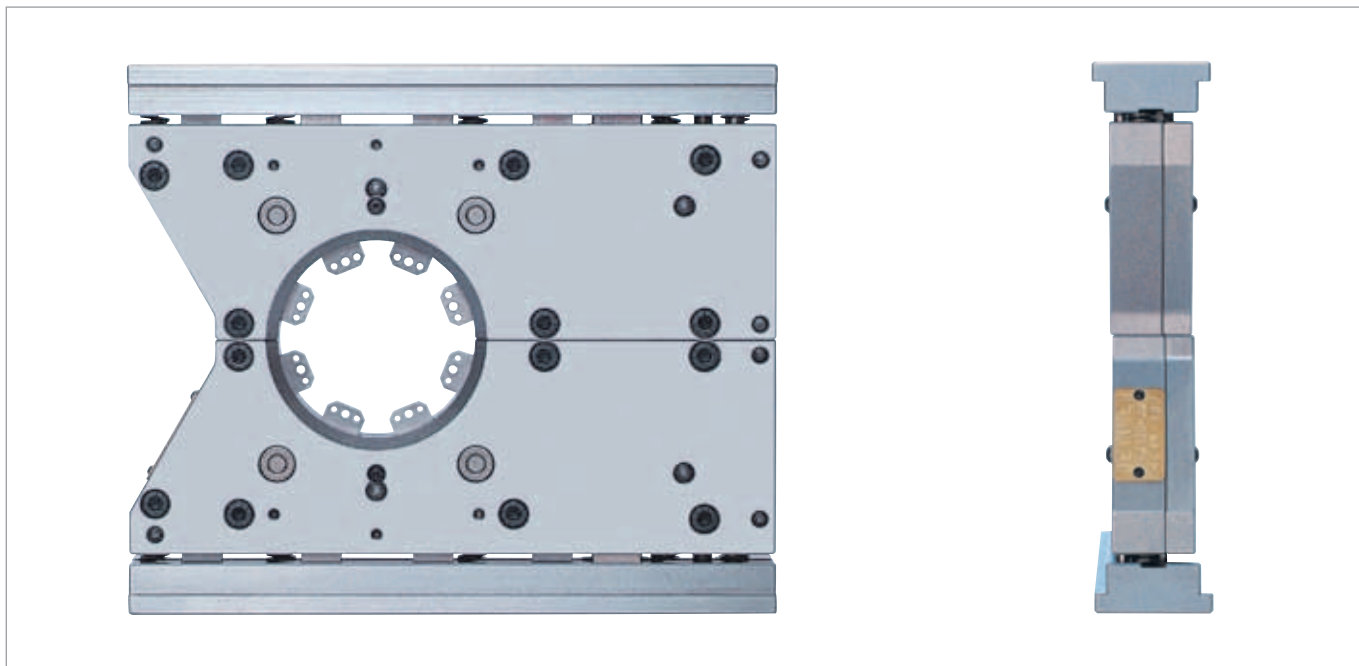

- Two separable halves for optimum component access
- Small size allows flexibility
- Intermeshing swaging segments guarantee 360° compression of MCR
- Interchangeable swaging jaws enhance quick-change features
- Optional arrangement enables 2 rings to be installed only 45 mm apart

Two-Piece Swaging Tool OETIKER Compact

For Multi Crimp Rings

Technical data

External dimensions

316 x 268 x 58 mm (l x h x w)

Weight

ca. 22 kg (48 lbs)

MCR size range

Ring dimensions Ø 16 mm to Ø 60 mm outside diameter
with 8 replaceable swaging jaws

Press stroke

Segment stroke Ø 8 mm

OETIKER Multi Crimp Rings should be installed using the swaging tools developed for them. This ensures correct installation and the best possible product performance. The vertical-opening, Two-Piece Swaging Tools for OETIKER Multi Crimp Rings with its compact dimensions allows for the separation of the tool halves for optimum accessibility and automatic latching of the tool. Powered by an external force – for example a hydraulic press – the jaws interact to reduce the MCR diameter. Because the jaw segments overlap, optimum compression of the ring is achieved.

Tool type

Swaging Tool COMPACT

Item No.

13400538

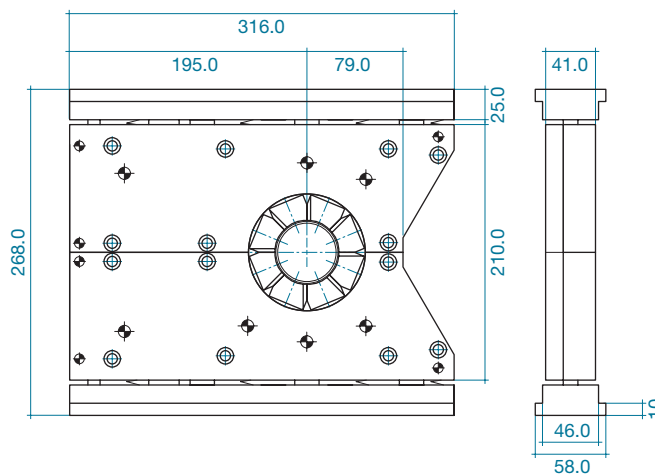

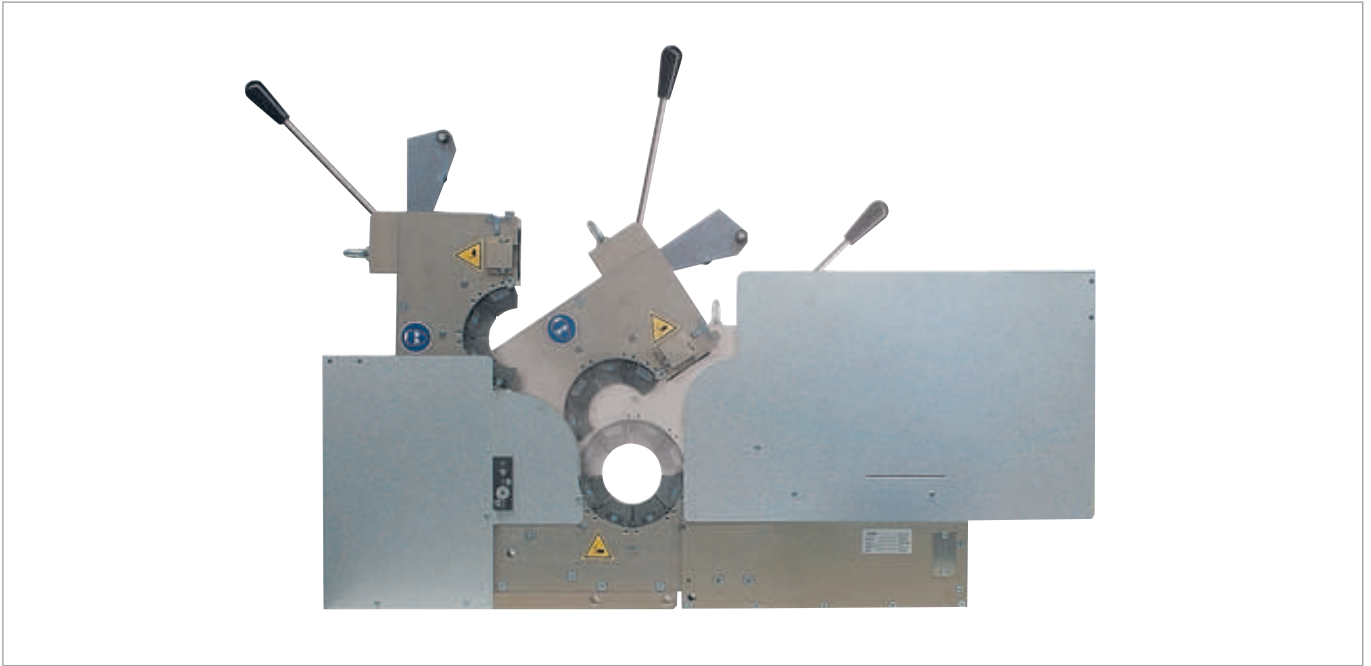

Single hinge for optimum accessibility

Automatic locking when tool is activated

Minimal width for parallel operation, enabling multiple single-axis installations

Intermeshing swaging segments guarantee 360° compression of MCR

Interchangeable swaging jaws enhance quick-change features

Hydraulic Swaging Tool OETIKER Flex

For Multi Crimp Rings

Technical data

External dimensions

Complete system including mobile bench:

1550 x 1450 x 700 mm (l x h x w)

Swaging press: 1270 x 660 x 80 mm (l x h x w)

Weight

Including mobile bench and hydraulic unit: ca. 220 kg

MCR size range

Ring dimensions 16 mm to 120 mm outside diameter with
8 replaceable swaging jaws

Ring dimensions 121 mm to 132 mm outside diameter with
special slides and jaws

Press stroke

Segment stroke 8 mm

OETIKER Multi Crimp Rings should be installed using the swaging tools developed for them. This ensures correct installation and the best possible product performance.

The hydraulic swaging tool OETIKER Flex has many advantages for industrial applications: For example, the tool can be opened for unrestricted accessibility with automatic latching and a very compact width. Powered by the integrated hydraulic drive, the jaws interact to reduce the MCR diameter. Because the jaw segments overlap, optimum compression of the ring is achieved.

Tool type	Item No.
Swaging tool Flex	13401010

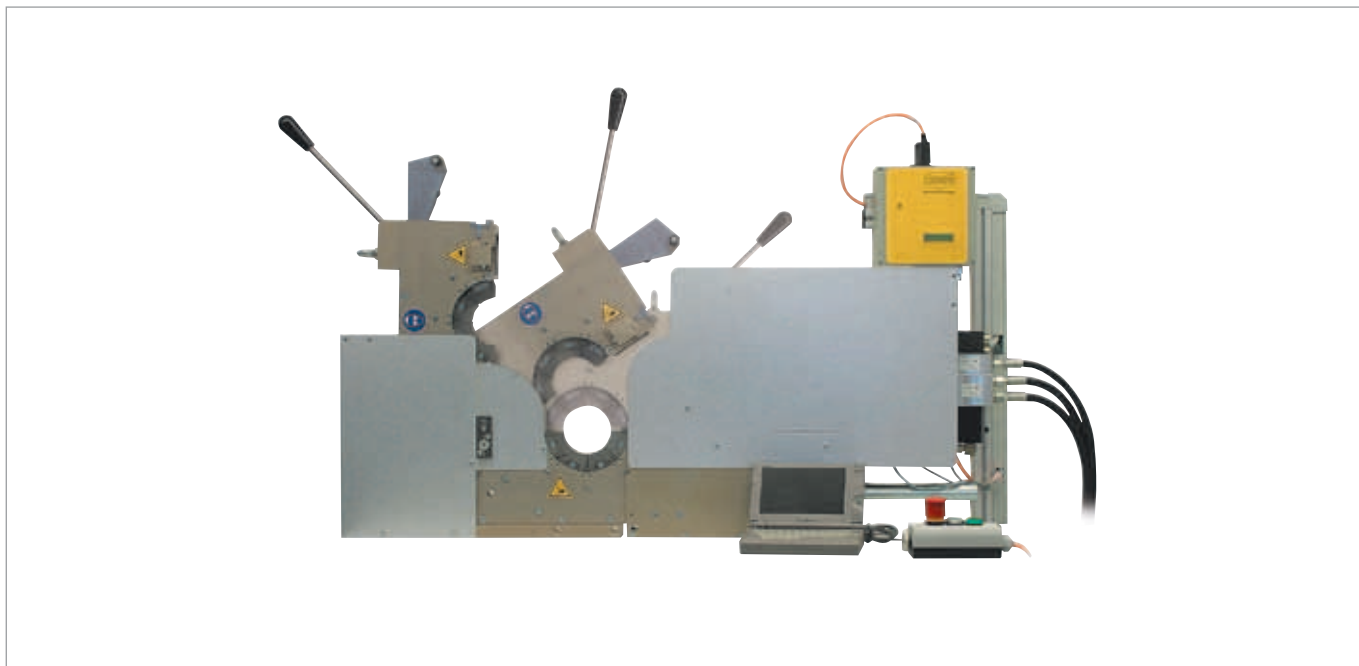

Process reliable installation with electronic monitoring of all specified parameters

Tool hinged for optimum accessibility

Fully automatic locking when tool is operated

Can be installed parallel for simultaneous closure of several MCRs

Intermeshing swaging segments guarantee 360° compression of MCR

Interchangeable swaging jaws enhance quick-change features

Electronically Controlled Hydraulic Swaging Tool OETIKER ELS 01

For Multi Crimp Rings

Technical Data

External dimensions

Complete system including mobile bench:

1550 x 1800 x 700 mm (l x h x w)

Swaging press: 1270 x 660 x 80 mm (l x h x w)

Weight

including mobile bench and hydraulic unit: ca. 240 kg

MCR size range

Ring dimensions 16 mm to 120 mm outside diameter with 8 replaceable swaging jaws

Ring dimensions 121 mm to 132 mm outside diameter with special slides and jaws

Press stroke

Segment stroke 8 mm

OETIKER Multi Crimp Rings should be installed using the swaging tools developed for them. This ensures correct installation and the best possible product performance.

The electronically controlled Swaging Tool OETIKER ELS 01 is an innovative closing concept providing reliable installation with electronic monitoring of all specified parameters. This tool offers many advantages for automotive and industrial applications, e.g. integration in automated processes, convenient programming using a PC, optimum component accessibility, automatic locking of the tool mechanism and low width. Powered by the integrated hydraulic drive, the jaws interact to reduce the MCR diameter.

Because the jaw segments overlap, optimum compression of the ring is achieved. Swaging can be carried out with either force or diameter priority. When using the force-priority method, the installation of OETIKER Multi Crimp Rings can compensate for variations in component tolerances. In addition, 100% documentation of closures is available by using the optional “Clamp Process Monitoring” software.

The thrust force of the hydraulic cylinder is set by changing the parameters at the ELS 01 control unit. This is accomplished by means of a PC, programming the specifications of a sequence of consecutive installations, or, optionally, using an external control signal. Specially adapted Test and Calibrating Equipment, based on the Calibrator CAL 01, is employed to calibrate the thrust force.

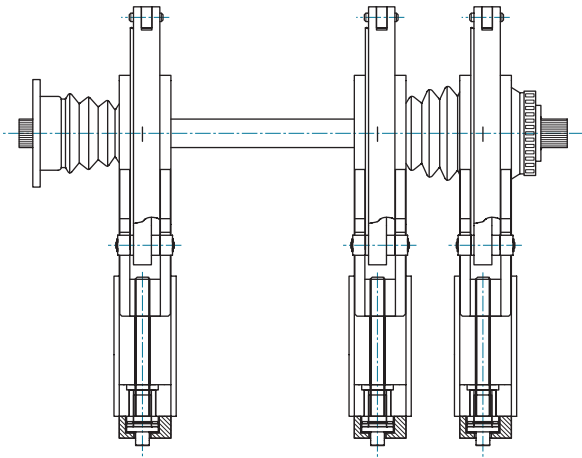

Example of an arrangement of swaging tools.
Rings can be closed simultaneously.

Tool type	Item No.
Swaging tool ELS 01	
With 3 x 400V/50–60Hz mains voltage	13401011
For other voltages	on request
CPM Clamp Process Monitoring Software	13600121
Calibrating Equipment for ELS 01	on request
Calibration gauges	on request



Ergonomic handling of OETIKER pincers

Saves time and reduces effort

Low-friction cable guide reduces wear, robust cast-aluminium

Can carry tools from 1 to 14 kg, stroke lengths up to 2.5 m

Specially adapted to OETIKER pincers

Spring balancers

Order information

Spring balancers without locking function

606 Materials: Cable: stainless steel/Housing: diecast aluminium

Item No.	Spring balancer	Recommended for	Weight supported	Self-weight	Stroke
60600136	Typ 9320	HO 2000–4000	1.0 ÷ 2.5 kg	2.0 kg	2.0 m
60600137	Typ 9321	HO 5000–7000	2.0 ÷ 4.0 kg	2.0 kg	2.0 m
60600138	Typ 9322	-	4.0 ÷ 6.0 kg	2.3 kg	2.0 m
60600139	Typ 9323	-	6.0 ÷ 8.0 kg	2.5 kg	2.0 m
60600140	Typ 9334	-	8.0 ÷ 10.0 kg	3.7 kg	2.5 m
60600141	Typ 9335	-	10.0 ÷ 14.0 kg	4.0 kg	2.5 m

Spring balancers with locking function

These balancers have an additional mechanism which allows the load to be locked at any desired height.

606 Materials: Cable: stainless steel/Housing: diecast aluminium

Item No.	Spring balancer	Recommended for	Weight supported	Self-weight	Stroke
60600142	Typ 9341	HO 2000–7000	2.0 ÷ 4.0 kg	3.0 kg	2.5 m
60600143	Typ 9342	HO 5000–7000	4.0 ÷ 6.0 kg	3.3 kg	2.5 m
60600144	Typ 9343	-	6.0 ÷ 8.0 kg	3.6 kg	2.5 m
60600145	Typ 9344	-	8.0 ÷ 10.0 kg	3.8 kg	2.5 m



Space-saving and rational – tool hangs from its hose

Robust diecast aluminium housing

Weight range and stroke limits are adjustable

Additional safety mounting eye

Can carry tools from 1.2 to 5 kg, stroke lengths up to 1.35 m

Spring balancers with compressed air hose/ Air hose reel

Order information

Spring balancers with compressed air hose for rationally designed workplaces. Tough polyurethane hoses and high-quality springs guarantee a long service life and consistent operation. Compressed air hoses are adapted to OETIKER ME pneumatic pincers

Spring balancer with compressed air hose

Item No.	Spring balancer	Recommended for	Weight supported	Self-weight	Stroke
60600146	Type 9202	HO 2000ME–4000ME	1.2 ÷ 2.5 kg	1.3 kg	1.35 m
60600147	Type 9203	HO 5000ME–7000ME	3.0 ÷ 5.0 kg	1.4 kg	0.90 m

Air hose reel, standard type

Automatic air hose reel, including swivel mounting, weight 9 kg

606 Materials: Compressed air hose: PUR, textile reinforced, 98 Shore A, colour: blue/Housing: steel/Mechanism: steel or brass

Item No.	Designation	Dimension ins. x outs.	Threaded connection		Work length
			Entrance	Exit	
60600106	Type standard	9.5 x 13.5 mm	G1/4" A	G1/4" A	12 m



Comply with safety standard ISO 4414, EN 983

Plug in accordance with ISO 6150-B-12, AFNOR: B-12 NF E 49-053 and US: MIL-C-4109

Full flow, negligible loss of pressure

Simple operation, no force required

Compact design

OETIKER Swing Couplings SC Series B1

Temperature range

-20° to + 100°C (NBR)

-4° to + 212°F

Operating pressure

3 in Hg (100 mbar) to 360° psi (25 bar), connection/disconnection at maximum 200 psi (15 bar)

Materials, Seals

Direction to selection and ordering
see catalogue Swing Couplings SC

Compatible with

Industrial Interchange 1/4", AMFLO C20B, Hansen 1000,
Foster 3003, Parker B23, Cejn 310

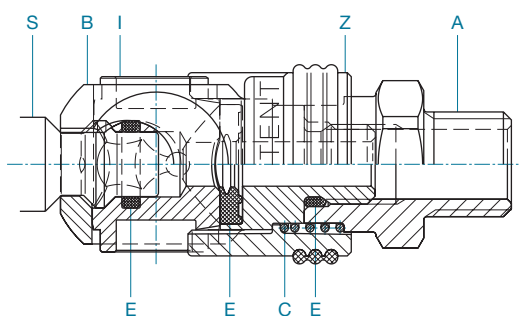

Material Code

A = Steel, nickel plated/aluminium

B = Steel, Tenifer treated

C = Stainless steel

E = Nitrile elastomer (NBR)

I = Surface hardened steel, nickel plated

S = Surface hardened steel, galvanized

Z = Zinc diecast, nickel plated,
orange plastic coating

Swing coupling
with female thread

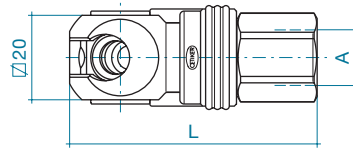

A	Item No.	L
G1/4	20500307	56.1
G3/8	20500308	57.6
G1/2	20500309	61.1
NPT1/4	20500311	56.1
NPT3/8	20500312	58.6
NPT1/2	20500313	64.6

with male thread

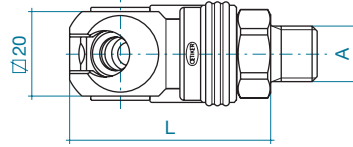

A	Item No.	L
G1/4	20500314	47.6
G3/8	20500315	47.6
G1/2	20500316	48.6
NPT1/4	20500317	48.8
NPT3/8	20500318	48.8
NPT1/2	20500319	48.6

with hose stem

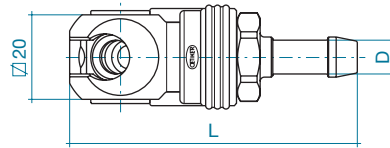

D	Item No.	L
6 mm 1/4"	20500320	68.1
8 mm 5/16"	20500321	68.1
10 mm 3/8"	20500322	68.1

with PUR compression fitting

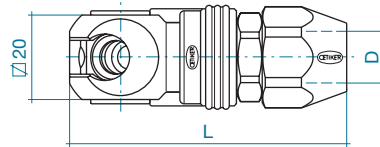

D	Item No.	L
6.5 x 10	20500324	62.6
8 x 12	20500325	65.6

Plug
with male thread

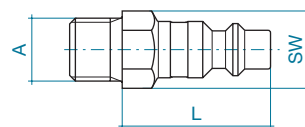

A	Item No.	L	SW
G1/8	25500011	34.0	14
G1/4	25500012	31.0	14
NPT1/4	25500014	30.7	14
NPT3/8	25500069	32.7	19

with female thread

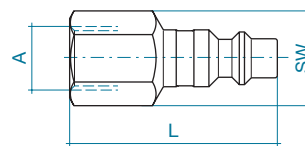

A	Item No.	L	SW
G1/4	25500016	43.0	17
NPT1/4	25500018	43.0	17
NPT3/8	25500274	45.0	19

with hose stem

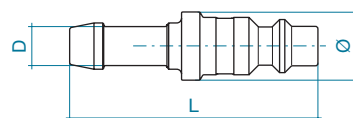

D	Item No.	L	\varnothing
6 mm 1/4"	25500019	51.0	14
8 mm 5/16"	25500020	51.0	14
10 mm 3/8"	25500021	51.0	14

For further versions and more information on our comprehensive range of couplings, please see the separate catalogue Swing Couplings SC.

OETIKER Swing Couplings SC

Series A1/K/C/D/E/E1

Series A1 [DN6] Series K [DN6] Series C [DN8] Series D [DN8] Series E [DN8] Series E1 [DN8]



Swing coupling
with female thread



A	Item No.	Item No.	Item No.	Item No.	Item No.	Item No.
G1/4	20500287	20500156	20500345	20500018	20500023	20500115
G3/8	20500288	20500157	20500346	20500019	20500024	20500116
G1/2	20500289	20500158	20500347	20500020	20500025	20500117
NPT1/4	20500291	20500160	20500348	20500034	20500052	20500118
NPT3/8	20500292	20500161	20500349	20500035	20500026	20500119
NPT1/2	20500293	20500162	20500350	20500036	20500027	20500120

with male thread



G1/4	20500294	20500163	20500351	20500053	20500028	20500121
G3/8	20500295	20500164	20500352	20500021	20500029	20500122
G1/2	20500296	20500165	20500353	20500022	20500045	20500123
NPT1/4	20500297	20500166	20500375	20500426	20500214	20500383
NPT3/8	20500298	20500167	20500354	20500037	20500030	20500124
NPT1/2	20500299	20500168	20500355	20500038	20500031	20500125

with hose stem



D						
6 mm 1/4"	20500300	20500169				
8 mm 5/16"	20500301	20500170	20500356	20500054	20500083	20500126
10 mm 3/8"	20500302	20500171	20500357	20500055	20500084	20500127
13 mm 1/2"			20500358	20500056	20500085	20500128

with PUR compression fitting



6.5 x 10	20500304	20500276		20500057		
8 x 12	20500305	20500277	20500360	20500058	20500087	20500130
11 x 16			20500361	20500059	20500088	20500131

Plug
with male thread



A	Item No.	Item No.	Item No.	Item No.	Item No.	Item No.
G1/8	25500000	25500093				
G1/4	25500001	25500091	25500023	25500032	25500041	25500101
G3/8		25500092	25500024	25500033	25500042	25500102
G1/2"				25500034		
NPT1/4	25500003	25500112	25500275	25500058	25500236	25500090
NPT3/8	25500066	25500117	25500177	25500059	25500044	25500089
NPT1/2"				25500060	25500045	

with female thread



G1/8		25500100				
G1/4	25500005	25500088	25500026	25500035	25500046	25500103
G3/8			25500027	25500036	25500047	25500105
G1/2"				25500037		
NPT1/4	25500007	25500119	25500276	25500061	25500237	25500104
NPT3/8	25500068		25500178	25500062	25500049	25500106
NPT1/2"				25500063	25500050	

with hose stem



D						
6 mm 1/4"	25500008	25500113				
8 mm 5/16"	25500009	25500114	25500029	25500038	25500051	25500107
10 mm 3/8"	25500010	25500115	25500030	25500039	25500052	25500108
13 mm 1/2"		25500116	25500031	25500040	25500053	25500109
16 mm 5/8"						25500110

For further versions and more information on our comprehensive range of couplings, please see the separate catalogue Swing Couplings SC.

Compressed air accessories



Compressed air service unit, filter-regulator, 30µm

With manual condensate release. All filter-regulators are supplied with mounting brackets and a 0–10 bar manometer

Materials: Housing: plastic, glass-fibre reinforced

Item No.	Designation	Connection	Flow rate (l/min)		Pressure range (bar)	
			economic	max.	Inlet max.	Outlet max.
60200004	Filter-regulator G1/4" I Series 40	G1/4" I	550	550	10	8
60200069	Filter-regulator NPT1/4" I Series 40	NPT1/4" I	550	550	10	8

Filter cartridge

Materials: Ceramic

Item No.	Designation
60200026	Filter cartridge for Series 40, 30µm

PUR compressed air hose

Light air hose for universal application in trade and industry

Material: Polyurethane with polyester textile reinforcement

Item No.	Designation	Dimensions IDxOD (mm)	Working press.	Colour exterior	Roll length
60100070	PUR air hose	6.0 x 10.0	15 bar	smooth, blue	100 m
60100071	PUR air hose	8.0 x 12.0	15 bar	smooth, blue	100 m

Spiral hose, pre-assembled with coupling and plug DN6 Series B1

Material: Spiral hose: PUR, 98 Shore A, colour: blue

Coupling: steel, zinc-plated

Plug-in nipple: steel, zinc-plated

Kink-protection spiral: black polyamide, unbreakable

Item No.	Designation	Dimensions ID x OD (mm)	Outside-Ø of spiral	length
60600029	Spiral hose	8.0 x 12.0	65 mm	4 m
60600030	Spiral hose	8.0 x 12.0	65 mm	6 m

Spiral hose, pre-assembled with rotatable threaded connections

Material: Spiral hose: PUR, 98 Shore A, colour: blue

Connections: brass, zinc-plated

Item No.	Designation	Dimensions ID x OD	Connection threads	Outside-Ø of spiral	Working length
60100181	Spiral hose	6.5 x 10.0	G1/4" A	52 mm	2 m
60100130	Spiral hose	6.5 x 10.0	G1/4" A	52 mm	4 m
60100131	Spiral hose	6.5 x 10.0	G1/4" A	52 mm	6 m

For further accessories, please see the separate accessory catalogue.



The OETIKER Group: www.oetiker.com

Headquarters Switzerland

Hans Oetiker AG
Maschinen- und Apparatefabrik
Oberdorfstrasse 21
CH-8812 Horgen (Zürich)
T +41 44 728 55 55
F +41 44 728 55 15
info@ch.oetiker.com

Austria

Hans Oetiker
Maschinen- und Apparatebau
Ges.m.b.H.
Eduard-Klinger-Strasse 19
A-3423 St. Andrä-Wördern
T +43 2242 33 994-0
F +43 2242 33 997
info@at.oetiker.com

Belgium

Oetiker Belgium N.V./S.A.
Maaltecenter – Blok “G”
Derbystraat 301
9051 Gent/St. Denijs-Westrem
T +32 9 252 25 55
F +32 9 252 25 56
info@be.oetiker.com

Canada

Oetiker Limited
203 Dufferin Street South
P.O. Box 5500
Alliston, Ontario L9R 1W7
T +1 705 435 4394
info@ca.oetiker.com

P. R. China

Oetiker Industries (Tianjin) Ltd.
10 Shuangchenzhong Road
Beichen High Tech Industrial Park
Tianjin 300400
T +86 22 2697 1183
F +86 22 2697 1380
info@cn.oetiker.com

Czech Republic

Hans Oetiker spol. s r. o.
Videnska 116
CZ-37833 Nová Bystrice
T +420 384 386513
F +420 384 386386
info@cz.oetiker.com

France

Oetiker Sarl
9, rue Jean Moulin
ZA du Pré Fusé
F-77348 Pontault-Combault Cedex
T +33 1 60 29 90 39
F +33 1 64 40 90 23
info@fr.oetiker.com

Germany

Hans Oetiker
Metallwaren- & Apparatefabrik GmbH
Üsenbergerstrasse 13
D-79346 Endingen a. K.
T +49 76 42 6 84-0
F +49 76 42 6 84-125
info@de.oetiker.com

Kurt Allert GmbH & Co. KG

Postfach 1160
Austrasse 36
D-78727 Oberndorf a. N.
T +49 74 23 87 70-0
F +49 7 4 23 87 70-87
info@allert.oetiker.com

Hong Kong

Oetiker Far East Limited
2210 Tuen Mun Central Square
22 Hoi Wing Road
Tuen Mun NT
T +852 2459 8211
F +852 2459 8322
info@hk.oetiker.com

Hungary

Oetiker Hungaria KFT
Vasvári P. U. 11
H-9800 Vasvár
T +36 94 370 630
F +36 94 370 533
info@hu.oetiker.com

India

Oetiker India Private Ltd.
N-14, Additional Patalganga
Industrial Area
Village Chavane, Khalapur
Rasayani 410 220
Dist. Raigad
T +91 2192 250107-12
F +91 2192 250105
info@in.oetiker.com

Japan

Oetiker Japan Co. Ltd.
Kaneko Bldg. A
5-3-5 Nakamachi-dai, Tsuzuki-ku
Yokohama 224-0041
T +81 45 949 3151
F +81 45 949 3152
info@jp.oetiker.com

Netherlands

Oetiker Benelux B. V.
Hertzstraat 38
NL-6716 BT Ede
T +31 318 63 71 71
F +31 318 63 34 89
info@nl.oetiker.com

Spain

Oetiker España, S.A.
Pol. Ind. Las Salinas
C/Puente, 18
E-11500 El Puerto
de Santa María (Cádiz)
T +34 956 86 04 40
F +34 956 87 17 07
info@es.oetiker.com

United Kingdom

Oetiker UK Limited
Foundry Close
GB-Horsham, Sussex RH13 5PX
T +44 1403 26 04 78
F +44 1403 24 06 90
info@uk.oetiker.com

USA

Oetiker, Inc.
6317 Euclid Street
Marlette, Michigan 48453-0217
T +1 989 635 3621
F +1 989 635 2157
info@us.oetiker.com